

**BASCO®
WHITLOCK®
HUB-DESIGN
HEAT
EXCHANGERS**



API Heat Transfer

...world leaders in heat transfer technology

Experience, Innovation and Reliability.

World leader in Heat Transfer

American Precision Industries has grown to become North America's largest provider of industrial heat transfer equipment with four plants serving the process and refrigeration industries. Our product portfolio includes a variety of shell and tube, plate and frame, brazed plate and brazed aluminum designs. With a worldwide network of qualified representatives and rapid delivery of finished products, you can be assured of the best value.



Basco/Whitlock hub-design heat exchangers are available in straight and U-tube designs in a variety of materials, configurations and options.



New Products & Technologies

API has a team of professionals dedicated to product innovation. Project managers work with our centralized research team via a systematic development process. This assures that innovations are quickly converted to commercial products. Our research team focuses on the needs specific to the market; ease of operation, reliability, and competitive pricing. Our customers deserve nothing less.

Demand Flow Technology

API is committed to state-of-the-art manufacturing technologies. Demand Flow Technology, or DFT, is the driving factor in our production of standard heat exchangers. Partnering with our suppliers and customers, these proven methods result in reduced cycle times, increased flexibility, higher efficiencies, consistently high quality and reduced cost.



API Heat Transfer

Standard Designs Yield Cost-Effective Performance

With thousands of installed units worldwide, Basco/Whitlock Type HT, AHT and 550 "hub-design" heat exchangers are known as highly reliable, low cost and readily available for shipment.

API Heat Transfer remains the industry standard for product variety, value and long term reliability.

Models available from stock or with short lead times.

Pre-engineered designs from stocked components

Our line of Basco/Whitlock HT, AHT and 550 heat exchangers is extensive. We can provide you with models with a non-ferrous shell circuit or all 316 stainless steel construction with a variety of options. Models with shell diameters from 2" through 12", in straight or U-tube designs, with 1/4", 3/8" and 5/8" tube diameters are readily available. A variety of connections, hub orientations and materials of construction are available to meet virtually any OEM or industrial requirement.

These standard heat exchangers reflect the latest in heat transfer design technology. Assembled in state-of-the-art manufacturing facilities, they are available to meet most new installation, replacement or OEM requirements. Even "custom" units are assembled from standardized components and are quickly available at "standard" costs. Whatever your need, API will work with you to design and manufacture the right equipment quickly and cost effectively.

Depth in applications, designs and manufacturing

API provides products for a broad range of duties.

- Compressor skids
- Stationary engines
- Refrigeration
- Hydraulic systems
- Turbine skids
- Vapor service
- Molding machines
- Marine applications
- Sterilizing

If your application falls outside these models, we can provide TEMA heat exchangers, plate technology, air cooled technology or refrigeration models.



Basco/Whitlock Type HTR U-tube designs are available in non-ferrous or stainless steel construction. Tubes can be seal welded or strength welded.

Cast Iron, Bronze or Stainless Steel End Bonnets.

One, Two or Four Pass Models are available.

Removable mounting feet with slotted holes can be reversed or rotated for quick, easy installation.

Shell ports available in NPT, SAE or threaded O-ring designs. Hubs can be rotated in 90° increments.

Generous entrance dome provides superior flow distribution and reduced pressure drop.

Tubes available in copper, admiralty, copper-nickel, stainless steel or special materials.

Precision cut baffles provide minimum clearances for controlled flow. Most models feature collared design for excellent tube support.

Shells are available in brass or 316 stainless steel.

Models available in straight and fixed or removable U-tube designs.

A Variety of Shell and Tube Models to meet your Specific Needs

Hub-Design Offers Flexibility

There is an extensive variety of small diameter shell and tube heat exchangers available from API. For service where ferrous metal is not desirable, such as in most water to water applications, Basco/Whitlock Hub-Design heat exchangers offer a wide range of sizes, designs, and materials of construction to provide maximum performance and minimal cost. While very similar in overall construction, each model offers unique and important benefits.



Basco/Whitlock type HT heat exchangers are available with modifications for use as refrigerant evaporators or condensers.

Interchangability and Application Flexibility

Type HT heat exchangers have been in production since 1965. Standard HT models feature low-cost, non-ferrous construction with brass shell, brass tubesheet and straight copper tubes. End bonnets are cast iron. Numerous options including special materials and nozzle orientation are available.

Type AHT heat exchangers feature all 316 Stainless Steel construction in a wide variety of configurations. Modified units are suitable for critical service where ultra-clean conditions are paramount. Options include seal welding of tube to tube sheet joints and polished surfaces for pharmaceutical and food processing applications.

Type HTR and AHTR feature a removable tube bundle design allowing shellside cleaning and bundle replacement, rare in a low cost small diameter design where tubesheets are typically fixed. Available in non-ferrous or stainless designs.

Type 550 Heat Exchangers offers users of competitive brands the ability to realize better overall value in their heat exchanger purchases. Engineered and manufactured to be dimensionally interchangeable with certain ITT Standard and Thermal Transfer models, Basco/Whitlock 550 models feature collared baffles that minimize fluid by-pass for maximum thermal performance. Spare parts, including bonnets and gaskets, are also interchangeable.

Port Location and Other Options

To meet certain specialized applications, the products are available with shell side connections in NPT, SAE threaded or O-ring designs. SAE 4-bolt side connections are available on the Type 550 models through 8" shell sizes. Special models with ANSI flanges are available for either shell or tube side connections. Nozzels can be rotated 90° in any direction on either side.

Tube side pass arrangements can be easily converted from single, two and four pass designs by merely changing end bonnets and gaskets. Provided the overall required heat transfer rate is maintained, this feature allows the flexibility to modify flow rates and pressure drops as process conditions change.

Hub-design heat exchangers provide solid advantages:

- Non-ferrous design for increased corrosion resistance. Suitable for water in the shell service.
- Allows the maximum number of tubes to be placed within a given shell diameter for better efficiency.
- Shell connections are closer to the tubesheet for better tube surface utilization and effective heat transfer.
- Domed shell nozzle design reduces entrance velocity and pressure drop for increased shell flow capability.



Larger diameter heat exchangers come with formed mounting feet or can be manufactured with other mounting methods as required.



Steam Service

Type HT models are excellent choices for highly reliable heat exchangers in steam service where steam is in the shell at steam pressures of 144 psig or less and temperatures are less than 350°F. Type AHT stainless steel heat exchangers are capable of pressures of up to 240 psig and 600°F. Both units can be mounted horizontally or vertically.

When it is desirable to have steam in the tubes, we recommend our type HTR or AHTR models with U-tubes which provides a number of operational advantages over straight tubes. U-tube models can be manufactured with or without removable bundles. U-tubes are free to expand and contract independently so that they tolerate higher differential temperatures than what is practical in fixed tube designs.

ASME Code Stamp

To meet certain applications, your Type HT or AHT vessel can be modified to meet ASME Section VIII, Division 1 requirements and stamped accordingly. This applies to 4" models and larger. ASME Code inspection, documentation and U-1 Forms are included in such cases. Code heat exchangers are assembled from stocked components to assure prompt delivery. Design modifications and material substitutions can be made as required. Type 550 heat exchangers can not be code stamped.

ASME CODE RATINGS					
TYPE	DESIGN PRESSURE PSIG (kPa)		TEST PRESSURE PSIG (kPa)		DESIGN TEMPERATURE °F (°C)
	Shell Side	Tube Side	Shell Side	Tube Side	Both Sides
HT	165 (1137)	200* (1378)	250 (1723)	300 (2068)	300 (149)
AHT 2"-8"	240 (1654)	200* (1378)	360 (2482)	300 (2068)	400 (204)
AHT 10"-12"	150 (1034)	150 (1034)	225 (1551)	225 (1551)	400 (204)

* Except for cast iron heads - 160 psig max and all 8" single-pass 125 psig max with ASME Code Stamp. 2" and 3" models cannot be Code Stamped

Related Heat Transfer Products

Basco/Whitlock Type 500 Heat Exchangers are a series of standardized designs constructed *without* hubs. They feature a steel or stainless steel shell welded directly to the tubesheet. Numerous options include materials of construction and nozzle orientation. Manufactured in high volume on a DFT production line, Type 500 heat exchangers are consistently high quality and cost effective. Information on the Type 500 heat exchanger is contained in a separate product bulletin.

API Heat Transfer manufactures a wide variety of equipment to suit specific needs. If your application falls outside the capabilities of the products detailed here, we can provide TEMA heat exchangers to 60" in diameter, plate heat exchangers and brazed aluminum designs for air and liquid cooling. Contact your API Heat Transfer sales representative, or API directly toll-free at 1-877-API HEAT.

API Heat Transfer

Products tailored for diverse markets

Applications Include:

- *Lube Oil*
- *Engine Jacket Water*
- *Gas Cooling*
- *Hydraulic Oil*
- *Refrigerant Evaporating*
- *Demineralized Water*
- *Jet Fuel*
- *Food Processing*
- *Distillates*
- *Vegetable Oils*
- *Heat Transfer Fluids*
- *Electrolytes*
- *Refrigerant Condensing*
- *Paints and Coatings*
- *Vapor Recovery*
- *Many Other Uses*

Basco/Whitlock Type 550

API Heat Transfer

Non-Ferrous, Straight Tube, Fixed Tube Sheet Design



Basco/Whitlock Type 550 Heat Exchangers are available from 2" thru 8" in diameter and up to 96" long. Polished "Show" model shown.

High Efficiency - Low Cost

Type 550 heat exchangers are well suited for relatively non-fouling shell-side fluids. Made from non-ferrous shell side components, it is suitable for water and other liquids that could cause corrosion in steel shell designs. Many models are dimensionally interchangeable with other brands.

Product Nomenclature

Size...

6 - Y - 36

Shell Tube Tube
Dia. OD Length

Type...

550 - 1 - A - CI

Core Tube Baffle Bonnet
Assy Pass Space Matl

Materials of Construction

Shell Brass
Tubes Copper or Admiralty
Tube Sheet Aluminum Bronze
Bonnets Cast Ductile Iron
Baffles Brass with Collars
Bolting Alloy Steel
Gaskets Compressed Fiber
Brackets Steel

Standard Ratings

Design Pressure

Shell Side 300 psi, 2068 kPa
Tube Side 150 psi, 1031 kPa

Test Pressure

All units are tested pneumatically

Design Temp 300°F, 149°C

Common Specifications...

Type 550 Heat Exchangers

Model	Shell Dia.	Tube Length	Surface		Connection Size			
			1/4"	3/8"	Shell	1-Pass	2-Pass	4-Pass
2-8		8	1.2					
2-12	2-1/8"	12	1.8		1	3/4	N/A	N/A
2-14		14	2.1					
2-24		24	3.6					
3-8		8	2.4					
3-12		12	3.6					
3-14	3-1/8"	14	4.3		1	1-1/2	1	3/4
3-18		18	5.5					
3-24		24	7.3					
3-30		30	9.1					
4-12		12	7.1					
4-14		14	8.3					
4-18	4-1/8"	18	10.6		1-1/2	2	1-1/4	3/4
4-24		24	14.1					
4-30		30	17.7					
4-36		36	21.2					
5-12		12	11.0	7.9				
5-14		14	12.8	9.1				
5-18	5-1/8"	18	16.5	11.8	1-1/2	2-1/2	1-1/2	1
5-24		24	22.0	15.7				
5-36		36	33.0	23.6				
6-18		18	24.8	17.1				
6-24		24	33.0	22.8				
6-36	6-1/8"	36	49.5	34.2	2	3	2	1-1/2
6-48		48	66.0	45.6				
6-60		60	82.5	57.0				
8-24		24	57.3	41.2				
8-36		36	85.9	61.8				
8-48	8-1/8"	48	114.6	82.4	3	3	2-1/2	2
8-60		60	143.2	103.0				
8-72		72	171.8	123.6				
8-96		96	229.2	164.8				

Basco/Whitlock Type AHT

API Heat Transfer

All 316 Stainless Steel, Straight Tube, Fixed Tube Sheet



Basco/Whitlock Type AHT Stainless Steel Heat Exchangers are available from 2" thru 12" in diameter and up to 96" long.

High Efficiency - Low Cost

Type AHT heat exchangers feature all 316 Stainless Steel shell construction. They are especially suited for applications involving corrosive vapors and liquids and offers high strength and thermal efficiency. Available in fixed or removable U-tube designs. Models available with ASME Code Stamp.

Product Nomenclature

Size...

5 - Y - 14

Shell Tube Tube
Dia. OD Length

Type...

AHT - 1 - A - SS

Core Tube Baffle Bonnet
Assy Pass Space Matl

Materials of Construction

Shell	316 Stainless Steel
Tubes	316 Stainless Steel
Tube Sheet	316 Stainless Steel
Bonnets	Cast 316 Stainless Steel Cast Iron, Cast Bronze
Baffles	316 Stainless Steel
Bolting	Alloy Steel
Gaskets	Compressed Fiber
Brackets	Steel

Standard Ratings

Design Pressure Std Units 10" & 12"

Shell Side	240 psi	150 psi
Tube Side	200 psi	150 psi

Design Temp 400°F 400°F

Test Pressure

Shell Side	360 psi, 2,482 kPa
Tube Side	300 psi, 2,068 kPa

Common Specifications...

Type AHT Heat Exchangers

Model	Shell Dia.	Tube Length	Surface			Connection Size			
			1/4"	3/8"	5/8"	Shell	1-Pass	2-Pass	4-Pass
2-8	2-1/8"	8	1.3			3/4	3/4	N/A	N/A
2-12		12	2.0						
2-18		18	3.0						
2-24		24	4.0						
3-8	3-1/8"	8	2.8	1.8		1	1-1/2	1	3/4
3-12		12	4.1	2.8					
3-14		14	4.9	3.2					
3-18		18	6.2	4.1					
3-24		24	8.4	5.5					
3-30		30	10.4	6.9					
4-12	4-1/8"	12	7.6	5.1		1-1/2	2	1-1/4	1
4-14		14	8.8	5.9					
4-18		18	11.4	7.6					
4-24		24	15.2	10.2					
4-30		30	19.0	12.7					
4-36		36	22.8	15.3					
5-12	5-1/8"	12	12.0	8.2		1-1/2	2-1/2	1-1/2	1
5-14		14	14.1	9.6					
5-18		18	18.1	12.4					
5-24		24	24.1	16.5					
5-36		36	36.2	24.7					
6-18	6-1/8"	18	27.9	18.3		2	3	2	1-1/2
6-24		24	37.2	24.4	11.8				
6-36		36	55.8	36.5	17.7				
6-48		48	74.4	48.7	23.6				
6-60		60	93.0	60.8	29.4				
8-24	8-1/8"	24	62.4	42.4	24.8	3	4	2-1/2	2
8-36		36	93.5	63.6	37.3				
8-48		48	124.7	84.8	49.7				
8-72		72	187.1	127.2	74.6				
8-96		96	249.4	169.6	99.5				
10-36	10-3/4	36		103.7	54.9	4	5	3	2-1/2
10-48		48		138.3	73.3				
10-60		60		172.8	91.6				
10-72		72		207.4	109.9				
12-36	12-3/4	36		155.5	90.3	4	6	3	2-1/2
12-48		48		207.4	120.4				
12-60		60		259.2	150.5				
12-72		72		311.1	180.6				

U-Tube Bundle - Non-Ferrous or Stainless Construction

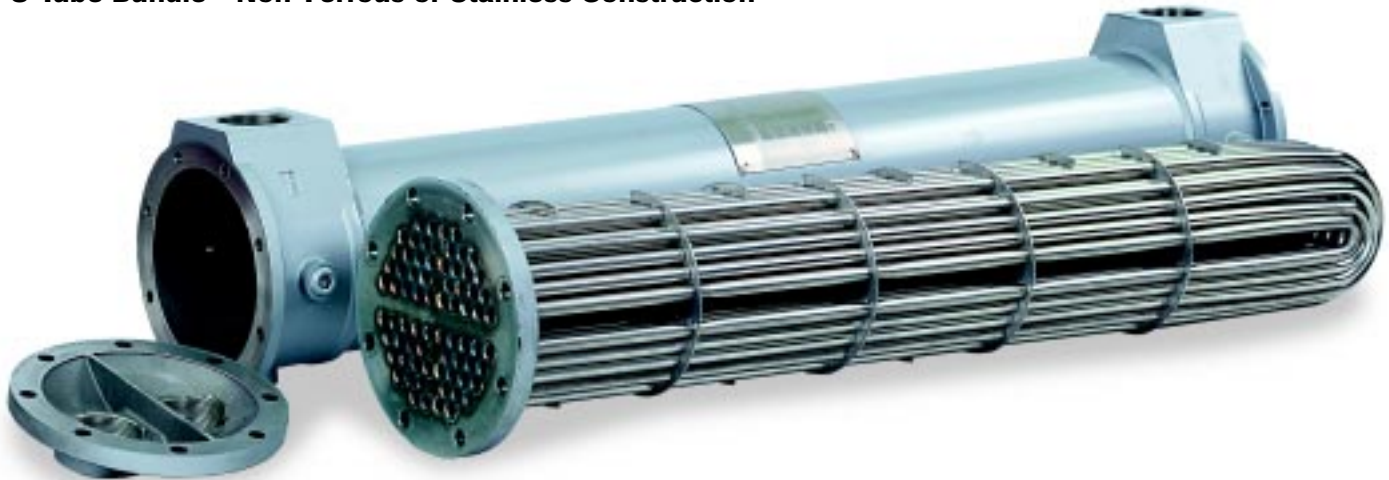

Basco/Whitlock Type HTR and AHTR Heat Exchangers are available from 3" thru 12" in diameter and up to 96" long in fixed or removable bundles.

High Efficiency - Low Cost

Type HTR and AHTR heat exchangers feature fixed or removable U-tube bundles. HTR features non-ferrous construction while AHTR has all 316 stainless steel shell materials. Models available with ASME Code Stamp. AHTR models in 10" and 12" shell diameters have fabricated heads.

Product Nomenclature

Size...

5 - Y - 14
 Shell Tube Tube
 Dia. OD Length

Type...

HTR - 1 - A - SS
 Core Tube Baffle Bonnet
 Assy Pass Space Matl

Materials of Construction

Shell 2-3" - Copper or SS
 4-8" - Red Brass or SS
 Tubes Copper, Admiralty or SS
 Tube Sheet Brass or Stainless Steel
 Bonnets Cast Iron, Bronze or SS
 Baffles Brass or SS
 Bolting Alloy Steel
 Gaskets Compressed Fiber
 Brackets Steel

Standard Ratings

Design Pressure - HTR

Shell Side 210 psi, 1447 kPa
 Tube Side 200 psi, 1378 kPa

Design Pressure - AHTR

Shell Side 240 psi, 1654 kPa
 Tube Side 200 psi, 1378 kPa

Design Temp HTR 300°F

Design Temp AHTR 400°F

Common Specifications...

Type HTR & AHTR Heat Exchangers

Model	Shell Dia.	Total Length	Surface			Connection Size			
			1/4"	3/8"	5/8"	Shell	1-Pass	2-Pass	4-Pass
3-12	3-1/8"	12	3.4	2.4		1	N/A	1	3/4
3-14		14	4.0	2.7					
3-18		18	5.1	3.5					
3-24		24	6.8	4.7					
3-30		30	8.5	5.9					
4-12	4-1/8"	12	6.6	5.0		1-1/2	N/A	1-1/4	1
4-14		14	7.7	5.8					
4-18		18	9.9	7.3					
4-24		24	13.1	9.7					
4-30		30	16.4	12.0					
4-36		36	19.7	14.4					
5-12	5-1/8"	12	11.0	7.2		1-1/2	N/A	1-1/2	1
5-14		14	12.8	8.3					
5-18		18	16.5	10.7					
5-24		24	22.0	14.2					
5-36		36	33.0	21.3					
6-18	6-1/8"	18	24.7	16.5	7.9	2	N/A	2	1-1/2
6-24		24	32.9	21.9	10.5				
6-36		36	49.4	32.9	15.7				
6-48		48	65.9	43.9	21.0				
6-60		60	82.4	54.9	26.2				
8-24	8-1/8"	24	65.1	42.4	23.5	3	N/A	2-1/2	2
8-36		36	96.3	63.6	35.3				
8-48		48	127.4	84.8	47.0				
8-60		60	158.6	106.0	58.9				
8-72		72	189.7	127.2	70.6				
8-96		96	252.0	169.9	94.2				
10-36	10-3/4	36		112.1	61.1	4	N/A	3	2-1/2
10-48		48		145.8	79.4				
10-60		60		179.6	97.7				
10-72		72		213.4	116.0				
12-48	12-3/4	48		221.0	120.9	4	N/A	3	2-1/2
12-60		60		272.5	148.4				
12-72		72		323.9	175.9				
12-84		84		375.4	203.4				
12-96		96		426.8	230.9				

Basco/Whitlock Type HT Heat Exchanger Dimensions

Size	COMMON DIMENSIONS									SINGLE PASS						A
	B	C	D	E	F	G	H	L	V	A	J	K	P	S	T	
2-8	6-1/4	5	12-3/4							11-1/4						
2-12	10-1/4	9	16-3/4	2-3/8	1-1/4	3-1/2	3/8 x 7/8	2-3/4	1-3/4	15-1/4	2-1/2	1-11/16	3-1/8	3/4	3/4	
2-18	16-1/4	15	22-3/4							21-1/4						
2-24	22-1/4	21	28-3/4							27-1/4						
3-8	6	5-1/4	13							11-1/2						10-7/8
3-12	10	9-1/4	17							15-1/2						14-7/8
3-14	12	11-1/4	19	4-3/16	1-1/4	3-1/2	3/8 x 7/8	2-3/4	2-7/16	17-1/2	2-3/4	2-7/16	3-1/8	1	1-1/2	16-7/8
3-18	16	15-1/4	23							21-1/2						20-7/8
3-24	22	21-1/4	29							27-1/2						26-7/8
3-30	28	27-1/4	35							33-1/2						32-7/8
4-12	9	9-3/4	17							16-1/2						15
4-14	11	11-3/4	19							18-1/2						17
4-18	15	15-3/4	23	5-5/8	2	5-1/4	1/2 x 1	2-3/4	3-3/16	22-1/2	3-3/4	3-1/8	3-3/8	1-1/2	2	21
4-24	21	21-3/4	29							28-1/2						27
4-30	27	27-3/4	35							34-1/2						33
4-36	33	33-3/4	41							40-1/2						39
5-12	9	9-7/8	16-7/8							16-3/4						15-1/8
5-14	11	11-7/8	18-7/8							18-3/4						17-1/8
5-18	15	15-7/8	22-7/8	6-1/2	2	5	1/2 x 1-5/8	3	3-9/16	22-3/4	3-7/8	3-11/16	3-7/16	1-1/2	2-1/2	21-1/8
5-24	21	21-7/8	28-7/8							28-3/4						27-1/8
5-36	33	33-7/8	40-7/8							40-3/4						39-1/8
6-18	14-3/8	15-1/8	23-5/8							23-1/4						22-1/16
6-24	20-3/8	21-1/8	29-5/8							29-1/4						28-1/16
6-36	32-3/8	33-1/8	41-5/8	7-1/2	2-1/2	6	1/2 x 1	3-1/16	4-3/16	41-1/4	4-7/16	4-1/4	4-1/16	2	3	40-1/16
6-48	44-3/8	45-1/8	53-5/8							53-1/4						52-1/16
6-60	56-3/8	57-1/8	65-5/8							65-1/4						64-1/16
8-24	19-1/8	20-1/2	30-3/4							30-7/8						30-1/4
8-36	31-1/8	32-1/2	42-3/4							42-7/8						42-1/4
8-48	43-1/8	44-1/2	54-3/4	9-11/16	3-1/2	8-1/4	5/8 x 1-1/8	3-11/16	5-3/8	54-7/8	5-7/8	5-5/8	5-3/16	3	4	54-1/4
8-72	67-1/8	68-1/2	78-3/4							78-7/8						78-1/4
8-96	91-1/8	92-1/2	102-3/4							102-7/8						102-1/4

Maximum tube length: 2" and 3" shell - 12 feet; 4" thru 8" - 20 feet. Tube sizes: 3" thru 8" 1/4" or 3/8"
 Note: 2" shell size available in 1/4" tubing only

SINGLE-PASS MODELS

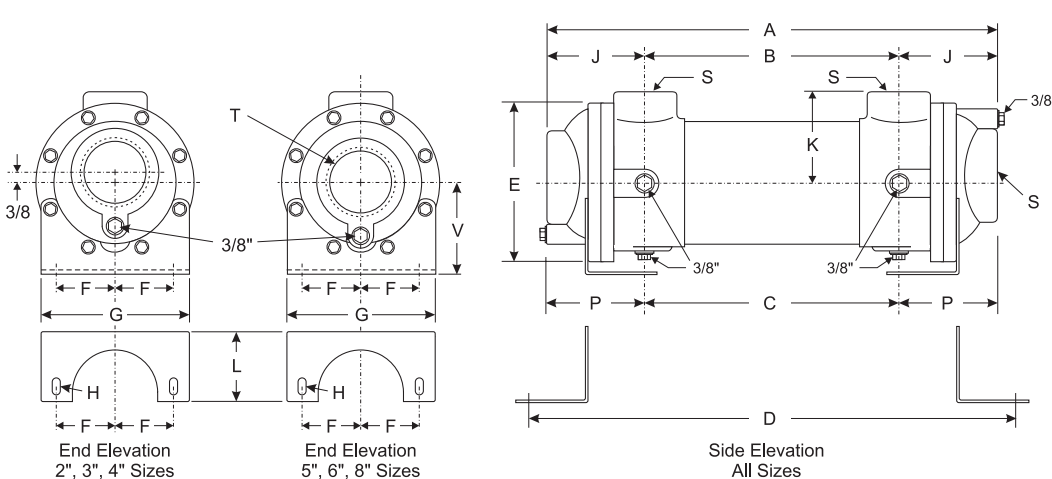

TWO-PASS

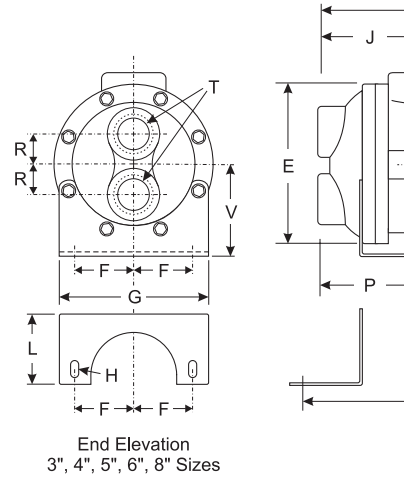

TWO PASS								FOUR PASS								Lbs.	
I	J	K	N	P	R	S	T	A	I	J	K	N	P	R	S		T
2-7/16	2-7/16	2-7/16	2-13/16	2-13/16	1	1	1	10-5/8 14-5/8 16-5/8 20-5/8 26-5/8 32-5/8	2-7/16	2-3/16	2-7/16	2-13/16	2-9/16	RV 1 RH 1	1	3/4	12 13 15 17 20 23
3	3	3-1/8	2-5/8	2-5/8	1-1/16	1-1/2	1-1/4	15 17 21 27 33 39	3	3	3-1/8	2-5/8	2-5/8	RV 15/16 RH 15/16	1-1/2	1	34 36 39 44 49 54
3-1/16	3-1/16	3-11/16	2-9/16	2-9/16	1-3/16	1-1/2	1-1/2	15-1/8 17-1/8 21-1/8 27-1/8 39-1/8	3-1/16	3-1/16	3-11/16	2-9/16	2-9/16	RV 3/4 RH 1-11/32	1-1/2	1	46 48 52 58 70
3-7/8	3-7/8	4-1/4	3-1/2	3-1/2	1-1/2	2	2	22-1/16 28-1/16 40-1/16 52-1/16 64-1/16	3-7/8	3-7/8	4-1/4	3-1/2	3-1/2	RV 15/16 RH 1-7/16	2	1-1/2	70 81 103 125 147
5-9/16	5-9/16	5-5/8	4-7/8	4-7/8	1-7/8	3	2-1/2	30-1/4 42-1/4 54-1/2 78-1/4 102-1/4	5-9/16	5-9/16	5-5/8	4-7/8	4-7/8	RV 1-3/8 RH 1-7/8	3	2	150 190 230 310 390

MODELS

FOUR-PASS MODELS

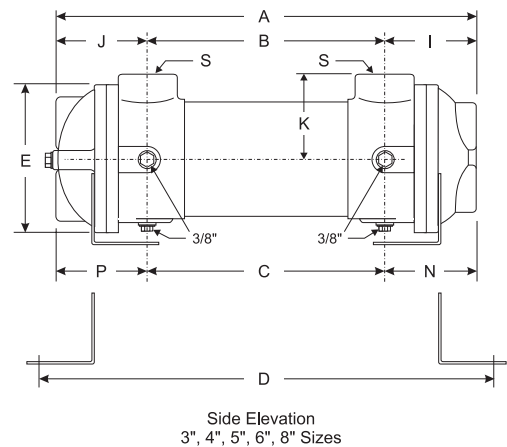
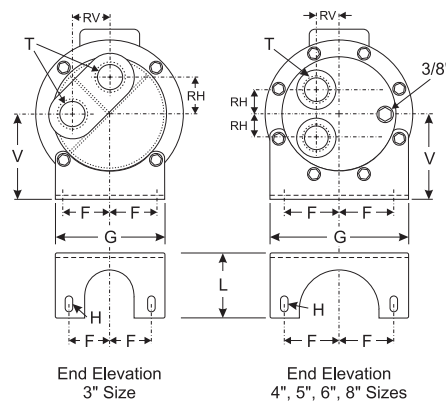
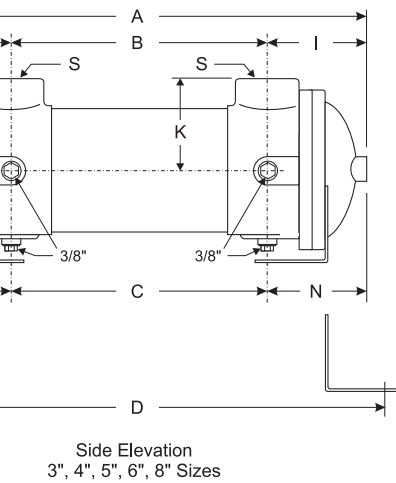

Basco/Whitlock Type 550 Heat Exchanger Dimensions

Size	COMMON DIMENSIONS									SINGLE PASS						A
	B	C	D	E	F	G	H	L	V	A	J	K	P	S	T	
2-8	6-1/4									11						
2-12	10-1/4			2-3/8						15	2-3/8	1-11/16		1	3/4	
2-14	12-1/4									17						
2-24	22-1/4									27						
3-8	6-1/8	6-3/4	11-3/8							11-1/4						10-3/4
3-12	10-1/8	10-3/4	15-3/8							15-1/4						14-3/4
3-14	12-1/8	12-3/4	17-3/8	4-3/16	1-3/4	4-1/2	1/2 x 1-1/2	2-1/4	2-7/16	17-1/4	2-9/16	2-7/16	2-5/16	1	1-1/2	16-3/4
3-18	16-1/8	16-3/4	21-3/8							21-1/4						20-3/4
3-24	22-1/8	22-3/4	27-3/8							27-1/4						26-3/4
3-30	28-1/8	28-3/4	33-3/8							33-1/4						32-3/4
4-12	9-1/8	10-7/8	15-1/2							16						15-5/8
4-14	11-1/8	12-7/8	17-1/2							18						17-5/8
4-18	15-1/8	16-7/8	21-1/2	5-7/8	1-3/4	4-3/4	1/2 x 1-1/2	2-1/4	3-1/2	22	3-7/16	3-1/8	2-9/16	1-1/2	2	21-5/8
4-24	21-1/8	22-7/8	27-1/2							28						27-5/8
4-30	27-1/8	28-7/8	33-1/2							34						33-5/8
4-36	33-1/8	34-7/8	39-1/2							40						39-5/8
5-12	9-1/8	9-3/4	14-3/8							16-1/2						16-5/16
5-14	11-1/8	11-3/4	16-3/8							18-1/2						18-5/16
5-18	15-1/8	15-3/4	20-3/8	6-1/2	2	5	1/2 x 1-1/2	2-1/4	3-1/2	22-1/2	3-11/16	3-5/8	3-3/8	1-1/2	2-1/2	22-5/16
5-24	21-1/8	21-3/4	26-3/8							28-1/2						28-5/16
5-36	33-1/8	33-3/4	38-3/8							40-1/2						40-5/16
6-18	14-1/2	15-1/2	18-9/16							23						22-3/4
6-24	20-1/2	21-1/2	24-9/16							29						28-3/4
6-36	32-1/2	33-1/2	36-9/16	7-1/2	2-1/2	6	1/2 x 1-1/2	2-5/8	4-1/8	41	4-1/4	4-1/4	3-3/4	2	3	40-3/4
6-48	44-1/2	45-1/2	48-9/16							53						52-3/4
6-60	56-1/2	57-1/2	60-9/16							65						64-3/4
8-24	19	20-1/2	25-5/16							31						30-1/2
8-36	31	32-1/2	37-5/16							43						42-1/2
8-48	43	44-1/2	49-5/16	9-3/4	3-1/2	8-1/4	5/8 x 1-5/8	3-5/8	5-3/8	55	6	5-5/8	5-1/4	3	3	54-1/2
8-72	67	68-1/2	73-5/16							79						78-1/2
8-96	91	92-1/2	97-5/16							103						102-1/2

Maximum tube length: 2" and 3" shell - 12 feet; 4" thru 8" - 20 feet. Tube sizes: 3" thru 8" 1/4" or 3/8"
 Note: 2" shell size available in 1/4" tubing only

SINGLE-PASS MODELS

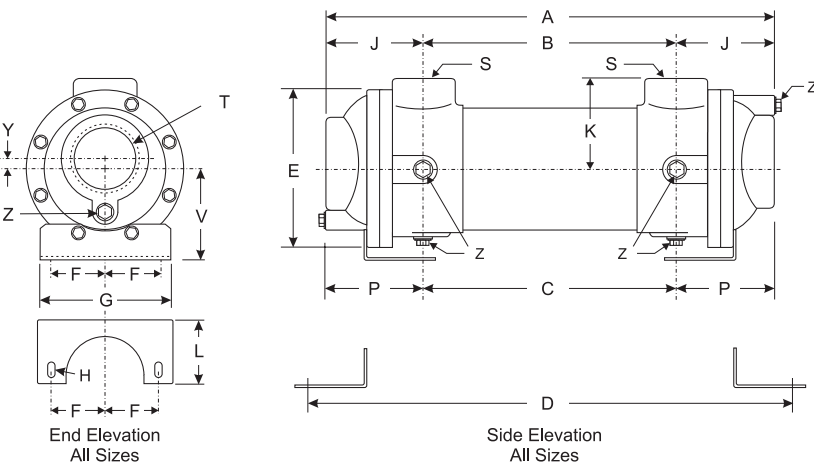

TWO-PASS

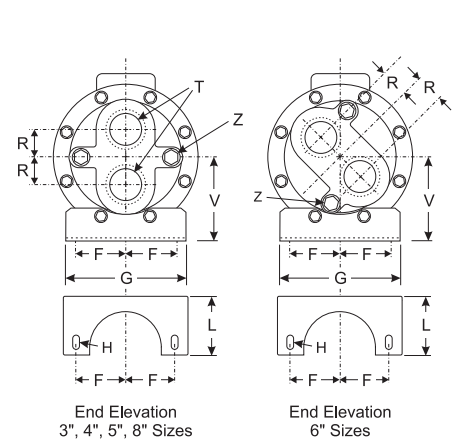

TWO PASS								FOUR PASS								Lbs.	
I	J	K	N	P	R	S	T	A	I	J	K	N	P	R	S		T
																	5 6 7 10
2-3/16	2-7/16	2-7/16	1-13/16	2-3/16	1	1	1	10-7/8 14-7/8 16-7/8 20-7/8 26-7/8 32-7/8	2-7/16	2-5/16	2-7/16	2-1/16	2-1/16	1	1	3/4	12 13 14 15 17 19
3-1/16	3-7/16	3-1/8	2-3/16	2-9/16	1-3/16	1-1/2	1-1/4	15-5/8 17-5/8 21-5/8 27-5/8 33-5/8 39-5/8	3-1/16	3-7/16	3-1/8	2-3/16	2-9/16	RV 1-1/16 RH 1-1/16	1-1/2	3/4	35 37 40 45 50 54
3-1/2	3-11/16	3-5/8	3-3/16	3-3/8	1-1/2	1-1/2	1-1/2	16-3/8 18-3/8 22-3/8 28-3/8 40-3/8	3-11/16	3-9/16	3-5/8	3-3/8	3-1/4	RV 1-11/16 RH 1-11/16	1-1/2	1	44 45 49 55 65
4	4-1/4	4-1/4	3-1/2	3-3/4	1-9/16	2	2	23 29 41 53 65	4-1/4	4-1/4	4-1/4	3-3/4	3-3/4	RV 2 RH 2	2	1-1/2	65 75 95 115 135
5-1/2	6	5-5/8	4-3/4	5-1/4	2-1/4	3	2-1/2	30-3/4 42-3/4 54-3/4 78-3/4 102-3/4	5-3/4	6	5-5/8	5	5-1/4	RV 2-5/8 RH 11/16	3	2	150 185 220 290 360

MODELS

FOUR-PASS MODELS

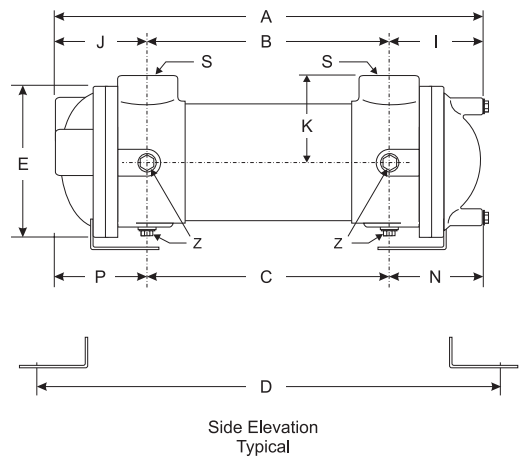
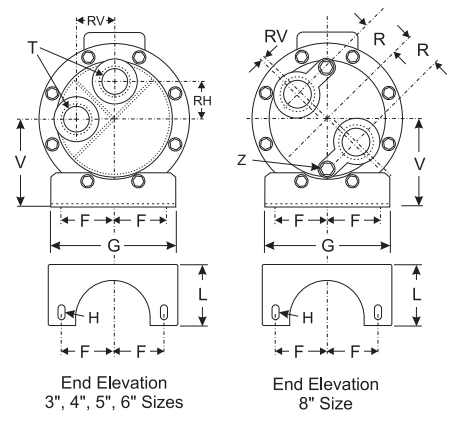
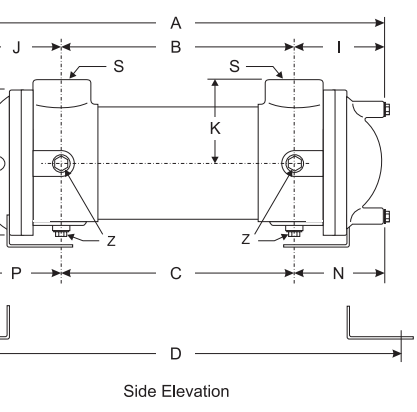

Basco/Whitlock Type AHT Heat Exchanger Dimensions

Size	COMMON DIMENSIONS									SINGLE PASS						A
	B	C	D	E	F	G	H	L	V	A	J	K	P	S	T	
2-8	6-1/4	5	12-3/4							11-1/4						
2-12	10-1/4	9	16-3/4	2-3/8	1-1/4	3-1/2	3/8 x 7/8	2-3/4	1-3/4	15-1/4	2-1/2	1-11/16	3-1/8	3/4	3/4	
2-18	16-1/4	15	22-3/4							21-1/4						
2-24	22-1/4	21	28-3/4							27-1/4						
3-8	6	5-1/4	13							11-1/2						10-7/8
3-14	12	11-1/4	19	4-3/16	1-1/4	3-1/2	3/8 x 7/8	2-3/4	2-7/16	17-1/2	2-3/4	2-7/16	3-1/8	1	1-1/2	16-7/8
3-24	22	21-1/4	29							27-1/2						26-7/8
3-30	28	27-1/4	35							33-1/2						32-7/8
4-14	11	11-3/4	19							18-1/2						17
4-18	15	15-3/4	23	5-5/8	2	5-1/4	1/2 x 1	2-3/4	3-3/16	22-1/2	3-3/4	3-1/8	3-5/8	1-1/2	2	21
4-24	21	21-3/4	29							28-1/2						27
4-36	33	33-3/4	41							40-1/2						39
5-14	11	11-7/8	18-7/8							18-3/4						17-1/8
5-18	15	15-7/8	22-7/8	6-1/2	2	5	1/2 x 1-5/8	3	3-9/16	22-3/4	3-7/8	3-11/16	3-7/16	1-1/2	2-1/2	21-1/8
5-24	21	21-7/8	28-7/8							28-3/4						27-1/8
5-36	33	33-7/8	40-7/8							40-3/4						39-1/8
6-24	20-3/8	21-1/8	29-5/8							29-1/4						28-1/16
6-36	32-3/8	33-1/8	41-5/8	7-1/2	2-1/2	6	1/2 x 1	3-1/16	4-1/8	41-1/4	4-7/16	4-1/4	4-1/16	2	3	40-1/16
6-48	44-3/8	45-1/8	53-5/8							53-1/4						52-1/16
6-60	56-3/8	57-1/8	65-5/8							65-1/4						64-1/16
8-36	31-1/8	32-1/2	42-3/4							42-7/8						42-1/4
8-48	43-1/8	44-1/2	54-3/4	9-11/16	3-1/2	8-1/4	5/8 x 1-1/8	3-11/16	5-3/8	54-7/8	5-7/8	5-5/8	5-3-16	3	4	54-1/4
8-72	67-1/8	68-1/2	78-3/4							78-7/8						78-1/4
8-96	91-1/8	92-1/2	102-3/4							102-7/8						102-1/4
10-36	27									48-1/4						45-3/8
10-48	39			13-3/4	3-3/8	8	5/8	1-1/2	7-1/4	60-1/4	10-5/8	9		4	5	57-3/8
10-60	51									72-1/4						69-3/8
10-72	63									84-1/4						81-3/8
12-36	25									48-1/4						45-1/2
12-48	37			15-3/4	4-1/4	10	5/8	1-3/4	8-1/4	60-1/4	11-5/8	11		4	6	57-1/2
12-60	49									72-1/4						69-1/2
12-72	61									84-1/4						81-1/2

Maximum tube length: 2" and 3" shell - 12 feet; 4" thru 8" - 20 feet. Tube sizes: 3" thru 8" 1/4" or 3/8"

Note: 2" shell size available in 1/4" tubing only

SINGLE-PASS MODELS

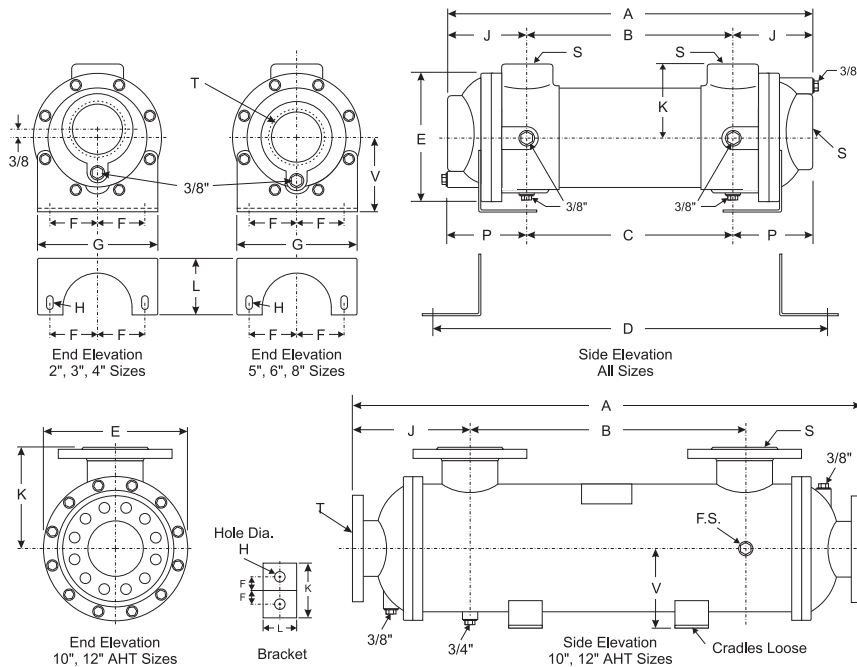

TWO-PASS MODELS

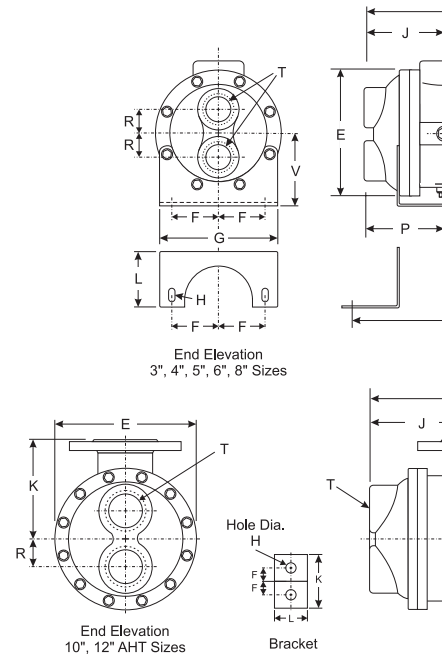

TWO PASS								FOUR PASS								Lbs.	
I	J	K	N	P	R	S	T	A	I	J	K	N	P	R	S		T
2-7/16	2-7/16	2-7/16	2-13/16	2-13/16	1	1	1	10-5/8 16-5/8 26-5/8 32-5/8	2-7/16	2-3/16	2-7/16	2-13/16	2-9/16	1	1	3/4	12 15 20 23
3	3	3-1/8	2-5/8	2-5/8	1-1/16	1-1/2	1-1/4	17 21 27 39	3	3	3-1/8	2-5/8	2-5/8	RV 15/16 RH 15/16	1-1/2	1	36 39 44 54
3-1/16	3-1/16	3-11/16	2-9/16	2-9/16	1-3/16	1-1/2	1-1/2	17-1/8 21-1/8 27-1/8 39-1/8	3-1/16	3-1/16	3-11/16	2-9/16	2-9/16	RV 3/4 RH 1-11/32	1-1/2	1	48 52 58 70
3-7/8	3-7/8	4-1/4	3-1/2	3-1/2	1-1/2	2	2	28-1/16 40-1/16 52-1/16 64-1/16	3-7/8	3-7/8	4-1/4	3-1/2	3-1/2	RV 15/16 RH 1-7/16	2	1-1/2	81 103 125 147
5-9/16	5-9/16	5-5/8	4-7/8	4-7/8	1-7/8	3	2-1/2	42-1/4 54-1/2 78-1/4 102-1/4	5-9/16	5-9/16	5-5/8	4-7/8	4-7/8	RV 1-3/8 RH 1-7/8	3	2	190 230 310 390
	9-3/16	9			2-1/4	4	3	45-3/8 57-3/8 69-3/8 81-3/8		9-3/16	9			RV 2 RH 2	4	2-1/2	467 562 656 751
	10-1/4	11			2-5/8	4	3	45-1/2 57-1/2 69-1/2 81-1/2		10-1/4	11			RV 2-1/4 RH 2-1/4	4	2-1/2	624 758 892 1027

MODELS

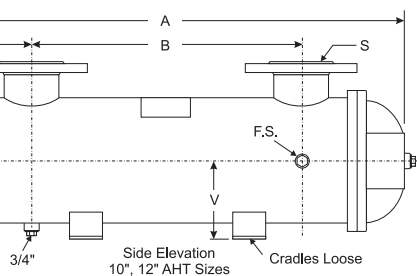
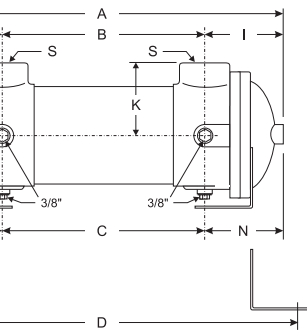

FOUR-PASS MODELS

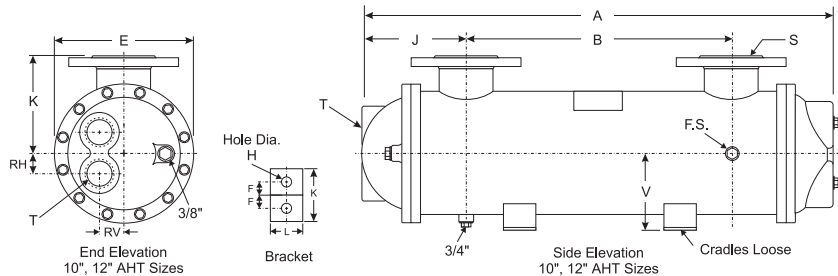
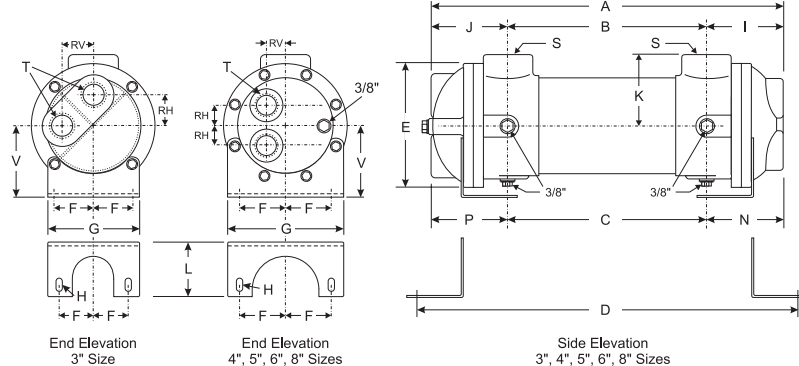

Basco/Whitlock Type HTR Heat Exchanger Dimensions

Size	COMMON DIMENSIONS									SINGLE PASS						
	B	C	D	E	F	G	H	L	V	A	J	K	P	S	T	A
3-12	12-1/4	11-1/2	19-1/4							-						16-3/16
3-14	14-1/4	13-1/2	21-1/4	4-3/16	1-1/4	3-1/2	3/8 x 7/8	2-3/4	2-7/16	-						18-3/16
3-18	18-1/4	17-1/2	25-1/4							-						22-3/16
3-24	24-1/4	23-1/2	31-1/4							-						28-3/16
3-30	30-1/4	29-1/2	37-1/4							-						34-3/16
4-12	13	13-3/4	21							-						18-1/8
4-14	15	15-3/4	23							-						20-1/8
4-18	19	19-3/4	27	5-5/8	2	5-1/4	1/2 x 1	2-3/4	3-3/16	-						24-1/8
4-24	25	25-3/4	33							-						30-1/8
4-30	31	31-3/4	39							-						36-1/8
4-36	37	37-3/4	45							-						42-1/8
5-12	12-1/2	13-3/8	20-3/8							-						17-5/8
5-14	14-1/2	15-3/8	22-3/8							-						19-5/8
5-18	18-1/2	19-3/8	26-3/8	6-1/2	2	5	1/2 x 1-5/8	3	3-9/16	-						23-5/8
5-24	24-1/2	25-3/8	32-3/8							-						29-5/8
5-36	36-1/2	37-3/8	44-3/8							-						41-5/8
6-18	18-3/8	19-1/8	27-5/8							-						24-11/16
6-24	24-3/8	25-1/8	33-5/8							-						30-11/16
6-36	36-3/8	37-1/8	45-5/8	7-1/2	2-1/2	6	1/2 x 1	3-1/16	4-3/16	-						42-11/16
6-48	48-3/8	49-1/8	57-5/8							-						54-11/16
6-60	56-3/8	61-1/8	69-5/8							-						66-11/16
8-24	24-7/8	26-5/16	36-9/16							-						33-11/16
8-36	36-7/8	38-5/16	48-9/16							-						45-11/16
8-48	48-7/8	50-5/16	60-9/16	9-11/16	3-1/2	8-1/4	5/8 x 1-1/8	3-11/16	5-3/8	-						57-11/16
8-72	72-7/8	74-5/16	84-9/16							-						81-11/16
8-96	96-7/8	98-5/16	108-9/16							-						105-11/16

Maximum tube length: 3" shell - 12 feet; 4" thru 8" - 20 feet. Tube sizes: 3" thru 8" 1/4" or 3/8"

TWO-PASS MODELS

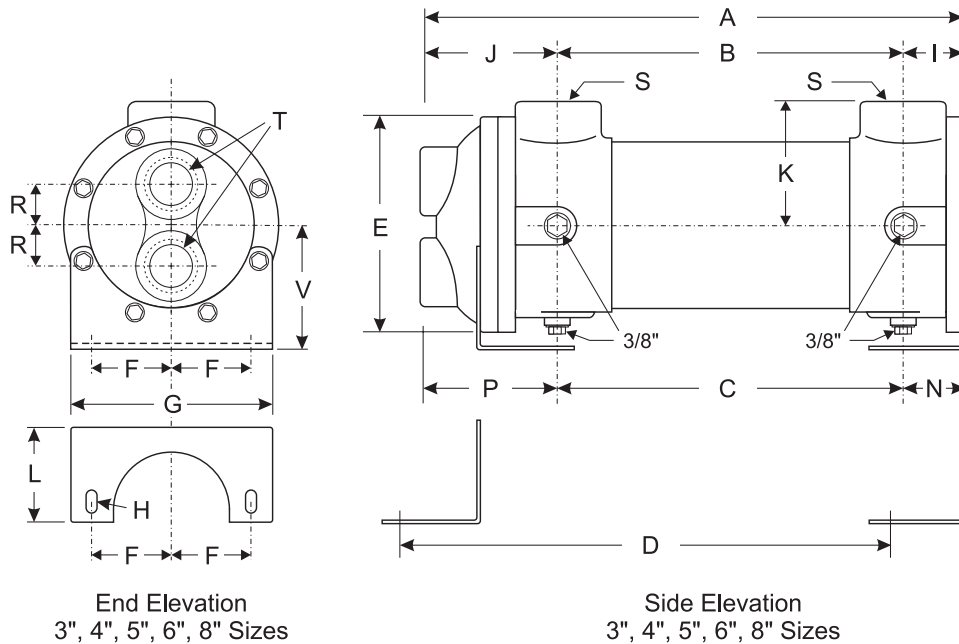

TWO PASS								FOUR PASS								Lbs.	
I	J	K	N	P	R	S	T	A	I	J	K	N	P	R	S		T
1	2-15/16	2-7/16	1-7/8	2-13/16	1	1	1	15-15/16 17-15/16 21-15/16 27-15/16 33-15/16	1	2-11/16	2-7/16	1-7/8	2-9/16	RV 1 RH 1	1	3/4	13 15 17 20 23
1-1/4	3-7/8	3-1/8	1-3/4	2-5/8	1-1/16	1-1/2	1-1/4	18-1/8 20-1/8 24-1/8 30-1/8 36-1/8 42-1/8	1-1/4	3-7/8	3-1/8	1-3/4	2-5/8	RV 15/16 RH 15/16	1-1/2	1	34 36 39 44 49 54
1-1/2	3-5/8	3-11/16	1-11/16	2-9/16	1-3/16	1-1/2	1-1/2	17-5/8 19-5/8 23-5/8 29-5/8 41-5/8	1-1/2	3-5/8	3-11/16	1-11/16	2-9/16	RV 3/4 RH 1-11/32	1-1/2	1	46 48 52 58 70
1-13/16	4-1/2	4-1/4	2-1/16	3-1/2	1-1/2	2	2	24-11/16 30-11/16 42-11/16 54-11/16 66-11/16	1-13/16	4-1/2	4-1/4	2-1/16	3-1/2	RV 15/16 RH 1-7/16	2	1-1/2	70 81 103 125 147
2-7/16	6-3/8	5-5/8	2-1/2	4-7/8	1-7/8	3	2-1/2	33-11/16 45-11/16 57-11/16 79-11/16 101-11/16	2-7/16	6-3/8	5-5/8	2-1/2	4-7/8	RV 1-3/8 RH 1-7/8	3	2	150 190 230 310 390

FOUR-PASS MODELS

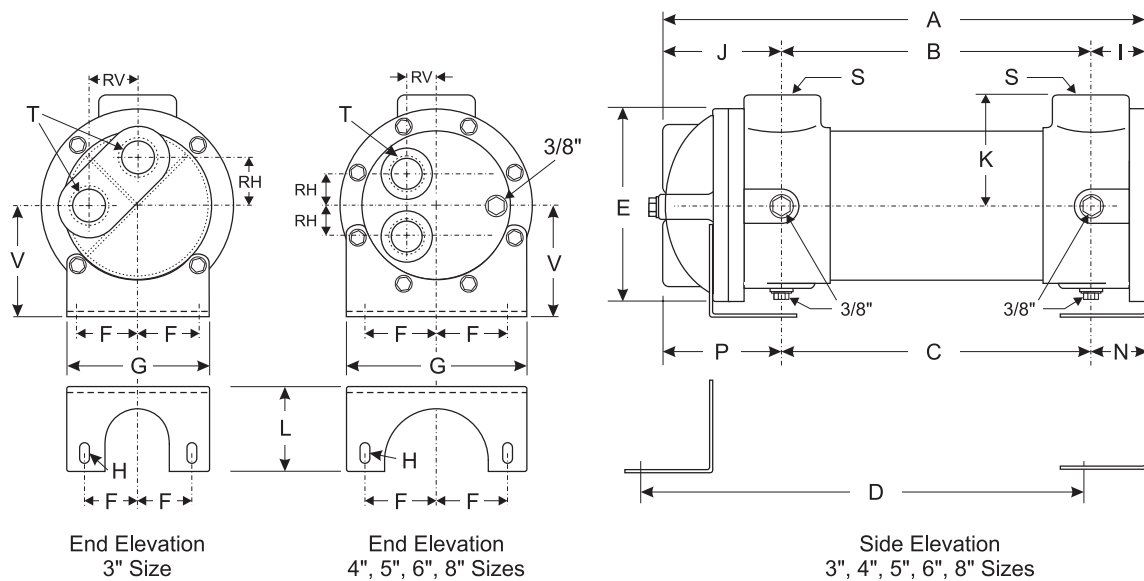

Basco/Whitlock Type AHTR Heat Exchanger Dimensions

Size	COMMON DIMENSIONS									SINGLE PASS						A
	B	C	D	E	F	G	H	L	V	A	J	K	P	S	T	
3-12	12-1/4	11-1/2	19-1/4							-						16-3/16
3-14	14-1/4	13-1/2	21-1/4	4-3/16	1-1/4	3-1/2	3/8 x 7/8	2-3/4	2-7/16	-						18-3/16
3-24	24-1/4	23-1/2	31-1/4							-						28-3/16
3-30	30-1/4	29-1/2	37-1/4							-						34-3/16
4-14	15	15-3/4	21							-						20-1/8
4-18	19	19-3/4	27	5-5/8	2	5-1/4	1/2 x 1	2-3/4	3-3/16	-						24-1/8
4-24	25	25-3/4	33							-						30-1/8
4-36	37	37-3/4	45							-						42-1/8
5-14	14-1/2	15-3/8	22-3/8							-						19-5/8
5-18	18-1/2	19-3/8	26-3/8	6-1/2	2	5	1/2 x 1-5/8	3	3-1/2	-						23-5/8
5-24	24-1/2	25-3/8	32-3/8							-						29-5/8
5-36	36-1/2	37-3/8	44-3/8							-						41-5/8
6-24	24-3/8	25-1/8	33-5/8							-						30-11/16
6-36	36-3/8	37-1/8	45-5/8	7-1/2	2-1/2	6	1/2 x 1	3-1/16	4-1/8	-						42-11/16
6-48	48-3/8	49-1/8	57-5/8							-						54-11/16
6-60	56-3/8	61-1/8	69-5/8							-						66-11/16
8-36	36-7/8	38-5/16	48-9/16							-						45-11/16
8-48	48-7/8	50-5/16	60-9/16	9-11/16	3-1/2	8-1/4	5/8 x 1-1/8	3-11/16	5-3/8	-						57-11/16
8-72	72-7/8	74-5/16	84-9/16							-						81-11/16
8-96	96-7/8	98-5/16	108-9/16							-						105-11/16
10-36	38-1/2									-						58-1/8
10-48	50-1/2			13-3/4	3-3/8	8	5/8	1-1/2	7-1/4	-						70-1/8
10-60	62-1/2									-						82-1/8
10-72	74-1/2									-						94-1/8
12-36	40									-						60-11/16
12-48	52			15-3/4	4-1/4	10	5/8	1-3/4	8-1/4	-						72-11/16
12-60	64									-						84-11/16
12-72	76									-						96-11/16

Maximum tube length: 3" shell - 12 feet; 4" thru 8" - 20 feet. Tube sizes: 3" thru 8" 1/4" or 3/8"

TWO-PASS MODELS

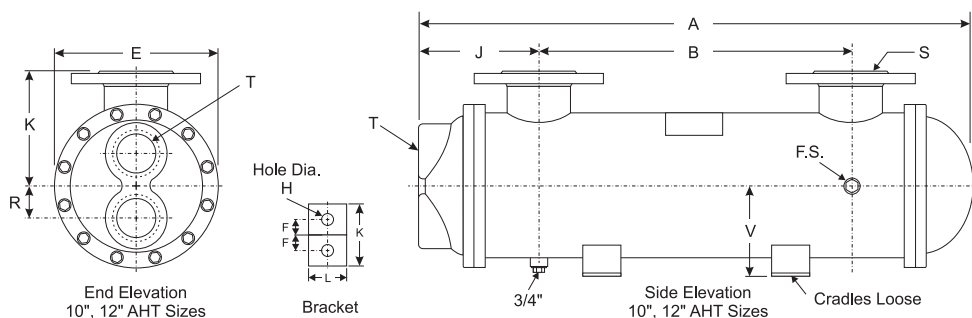
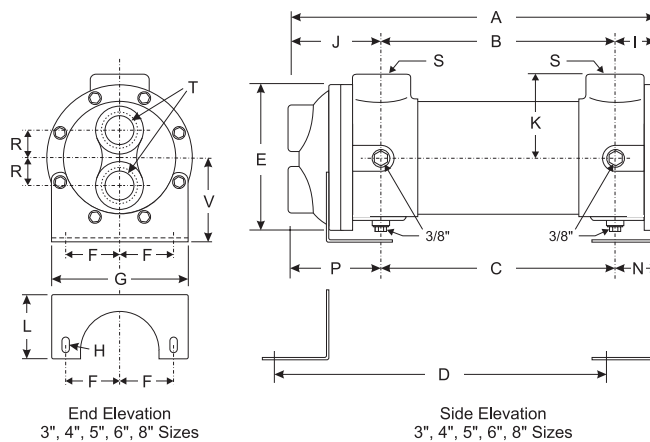

TWO PASS								FOUR PASS								Lbs.	
I	J	K	N	P	R	S	T	A	I	J	K	N	P	R	S		T
1	2-15/16	2-7/16	1-7/8	2-13/16	1	1	1	15-15/16 17-15/16 27-15/16 33-15/16	1	2-11/16	2-7/16	1-7/8	2-9/16	RV 1 RH 1	1	3/4	13 15 20 23
1-1/4	3-7/8	3-1/8	1-3/4	2-5/8	1-1/16	1-1/2	1-1/4	20-1/8 24-1/8 30-1/8 42-1/8	1-1/4	3-7/8	3-1/8	1-3/4	2-5/8	RV 15/16 RH 15/16	1-1/2	1	36 39 44 54
1-1/2	3-5/8	3-11/16	1-11/16	2-9/16	1-3/16	1-1/2	1-1/2	19-5/8 23-5/8 29-5/8 41-5/8	1-1/2	3-5/8	3-11/16	1-11/16	2-9/16	RV 3/4 RH 1-11/32	1-1/2	1	48 52 58 70
1-13/16	4-1/2	4-1/4	2-1/16	3-1/2	1-1/2	2	2	30-5/8 42-5/8 54-5/8 66-5/8	1-13/16	4-1/2	4-1/4	2-1/16	3-1/2	RV 15/16 RH 1-7/16	2	1-1/2	81 103 125 147
2-7/16	6-3/8	5-5/8	2-1/2	4-7/8	1-7/8	3	2-1/2	45-11/16 57-11/16 79-11/16 105-11/16	2-7/16	6-3/8	5-5/8	2-1/2	4-7/8	RV 1-3/8 RH 1-7/8	3	2	190 230 310 390
	11-1/4	9			2-1/4	4	3	58-1/8 70-1/8 82-1/8 94-1/8		11-1/4	9			RV 2 RH 2	4	2-1/2	467 562 656 751
	11-5/16	11			2-5/8	4	3	60-11/16 72-11/16 84-11/16 96-11/16		11-5/16	11			RV 2-1/4 RH 2-1/4	4	2-1/2	624 758 892 1027

FOUR-PASS MODELS

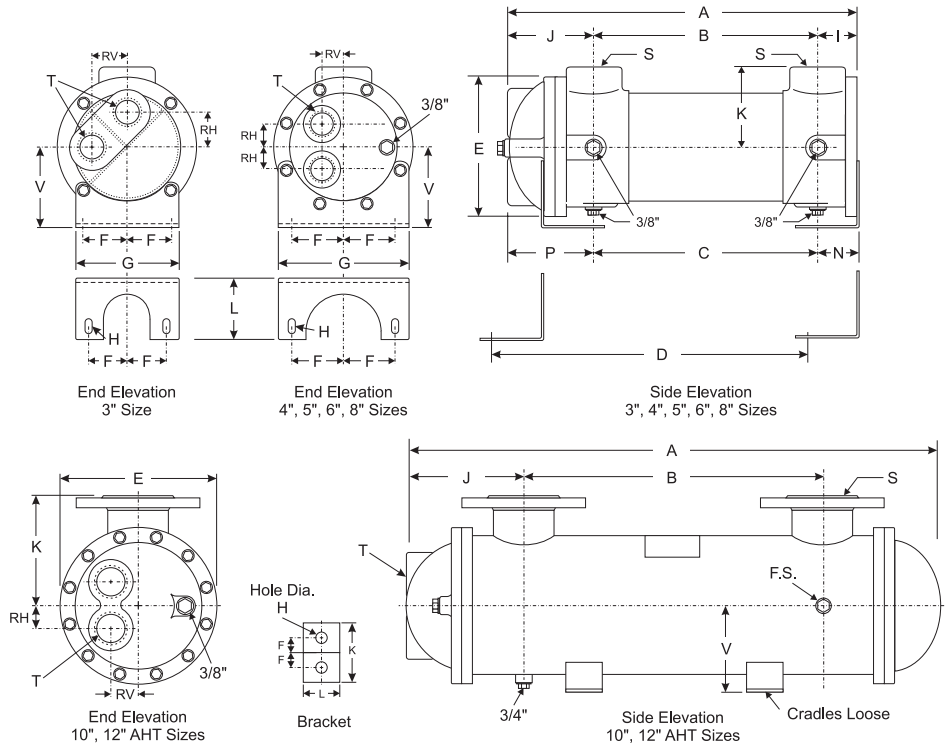

API Heat Transfer

*American Precision
Industries, Inc.*

API Airtech Inc. ISO-9001 Certified

Air Cooled Aluminum Heat Exchangers

91 North Street • P.O. Box 68

Arcade, New York 14009-0068

(716) 496-5755 • Fax: (716) 496-5776

API Basco Inc. ISO-9001 Certified

Basco/Whitlock Shell & Tube Heat Exchangers

2777 Walden Avenue

Buffalo, New York 14225

(716) 684-6700 • Fax: (716) 684-2129

API Ketema Inc.

Basco/Whitlock Shell & Tube Heat Exchangers

Acme® Refrigeration Equipment

2300 West Marshall Drive

Grand Prairie, Texas 75051

(972) 647-2626 • Fax: (972) 641-1518

www.apiketema.com

API Schmidt-Bretten Inc.

Plate Heat Exchangers

2777 Walden Avenue

Buffalo, New York 14225

(716) 684-6700 • Fax: (716) 684-2129

API Schmidt-Bretten GmbH.

ISO-9001 Certified

Plate Heat Exchangers

P.O. Box 1580 D-75005 Bretten

Pforzheimer Strasse 46

D-75015 Bretten, Germany

7252/53-101 • Fax: 7252/53-201

**Call your local API Sales Representative or
API directly toll-free at 1-877-API HEAT.**

Other Products Available from API Heat Transfer

OptiDesign®



Straight-tube, removable bundle exchangers made from standard components. Floating tube sheet for seal leak detection and easy maintenance. Diameters from 3" (7.62 cm) to 42" (106.68 cm). ASME, API, TEMA, ABS and other codes available.

Pipeline Aftercoolers



Straight tube, counterflow aftercoolers designed to yield cool, dry compressed air. Available with or without accompanying moisture separators and constructed to a wide variety of design codes. Diameters from 6" (15.24 cm) to 42" (106.68 cm).

TEMA Shell and Tube



A wide variety of TEMA types are available using pre-engineered or custom designs in various sizes and materials. Shell diameters from 6" (15.24 cm) to 60" (152.4 cm), ASME, TEMA, API, ABS, TUV, ISPESEL and other code constructions available.

Refrigerant Evaporators & Condensers



Off-the-shelf, standard units reflect the latest in heat exchanger technology for maximum performance and low cost. Ideal for OEM or aftermarket applications. Numerous design and material options are available. Tonnage capacity ranges from 5 to over 400 tons.

Extended Surface



Unique, patented plate-fin design for centrifugal or axial compressor intercooler and aftercooler applications and minimal pressure loss. Design eliminates separators. ASME code design is standard. Diameters from 20" (50.8 cm) to 120" (304.8 cm).

Air-Cooled Heat Exchangers



High efficiency, brazed aluminum coolers for cooling a wide variety of liquids and gases with ambient air. Lightweight, yet rugged. Capable of cooling multiple fluids in single unit. Models can be supplied with cooling fan and a variety of drives.

Plate Heat Exchangers



Compact units provide excellent heat transfer and small size. Plates are pressed from stainless steel, titanium and other alloys. Gaskets of nitrile, EPDM, Viton®, compressed fiber and Teflon® are used. Gasket-free welded and brazed designs available.

ACME® Packaged Chillers



Packaged chillers with or without pumping systems from 3 to over 400 tons with PLC controls available. Standard and custom designed chiller-barrels and condensers to 2,500 tons with same-day shipment on many units. DX and flooded evaporators available.