

C50-4

tubular and finned tubular elements

Thermal Products, Inc.
964 A Route 146
Clifton Park, NY 12065
(518) 877-0231
sales@thermalproducts.com
www.thermalproducts.com



electric heating and controls



Table Of Contents

| | |
|---|-------------|
| Construction | 1-2 |
| Quality Control | 2 |
| Physical & Electrical Specifications | 3 |
| Watt Density & Sheath Selection | 4-5 |
| Terminals, Insulators & Seals | 6-7 |
| Bending | 8-11 |
| Mounting Accessories | 12 |
| Limited Warranty | |



Introduction

INDEECO designs and manufactures commercial and industrial electric heating and control systems that set the industry standard for excellence. The company's heating solutions reflect more than 70 years of innovation, product quality and efficient service.

Our product offering ranges from the tubular heating elements described in this catalog to the most sophisticated, custom designed system. INDEECO's attention to detail and rigorous testing give worldwide customers premium products that they receive quickly and at a fair market price.

Construction

Standard Construction

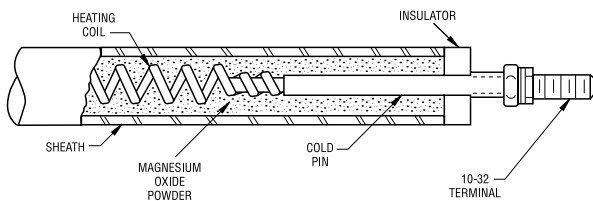

The cutaway view of a typical INDEECO tubular element shows its basic construction. A coil of the highest grade-resistance wire (80% nickel, 20% chromium) is precisely centered in a heavy gauge metal tube while the tube is filled with granular magnesium oxide powder. Terminal pins are welded or silver soldered to the resistance coil at each end to provide an unheated length near the terminals and to secure the coil in the magnesium oxide. Through rolling, the diameter of this assembly is reduced and the magnesium oxide compacted, insuring rapid heat transfer from the coil to the sheath, as well as high dielectric strength.

After compaction, the element is processed in one of three ways:

1. **Straight length elements** are sealed and appropriate terminals applied.
2. **Formed elements are annealed** and bent before they are sealed and terminated.
3. **Finned elements** are wound with a helical fin before they are sealed and terminated.

Two-Pass Construction

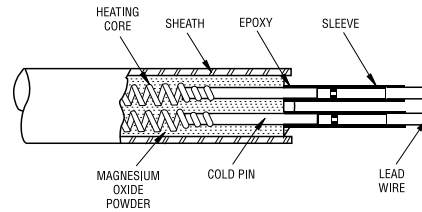

For applications requiring both terminations at the same end, either a U-bent or a two-pass element may be used. Two-pass elements, as shown in the cutaway view, have a U-bent coil inside the sheath and two leads or terminals at one end. The opposite end is sealed by welding or silver soldering. These elements are available in straight lengths, either finned or unfinned. They can be permanently mounted with a variety of factory-furnished mounting methods (see page 12). By contrast, standard elements in straight lengths must have a flexible electrical connection at one end to allow for thermal expansion.

Finned Construction

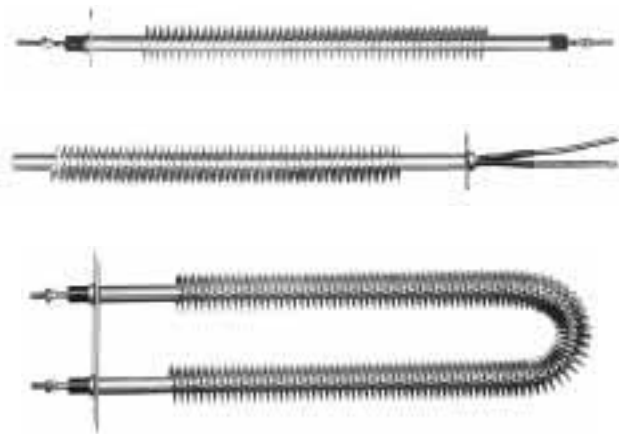

Standard Construction: A corrugated 304 stainless steel fin is helically wound on a .475" diameter 304 stainless steel element. To insure a permanent bond, each end of the fin is tack-welded to the element sheath. The entire assembly then goes through a computer controlled atmosphere furnace. This process prepares the element to be bent into a variety of configurations. Standard fin density is five fins per inch, while eight fins per inch can be furnished when specified.

Special Materials: .475" diameter elements can be furnished with monel fins and/or sheath. There are a variety of other exotic materials available that are useful for unique applications. Contact your local sales representative or INDEECO for the appropriate material for your application.

Construction/Quality Control

Construction Techniques

INDEECO construction techniques are designed to insure high quality and long life.

- **Rolling** – All standard diameter elements listed in this catalog are compacted through multi-stage rolls. This process insures uniform compaction of the magnesium oxide, a truly round cross section and a consistent diameter. This is critical if the element is being inserted into a machined hole.
- **Terminal Construction** – A threaded 10-32 stainless steel terminal is welded onto the cold pin for the standard construction. This technique allows the use of a relatively small diameter pin since it is not carrying the element current at its most critical point: connection to field wiring. The smaller pin also results in greater electrical clearances between the pin and the sheath, which is critical at higher voltages.

Stainless steel nuts and washers are furnished for field wiring. This hardware fits up to an integral shoulder with two flat sides on the terminal. Using an end wrench on the flats will prevent the terminal from rotating when connecting field wiring.

The terminal insulator and seal must be suitable for the temperature, voltage and atmospheric conditions of the application. INDEECO offers a wide variety of terminals, insulators and seals to meet virtually any combination of field conditions (see pages 6 and 7).

- **Recompaction** – In the process of bending, hairline cracks can develop in the compacted magnesium oxide. These cracks, in turn, can lead to overheating and coil failure, especially at high temperatures or high watt densities. To prevent such failures, we recompress most bends with a center-to-center diameter of 2" or less, eliminating cracks in the magnesium oxide.

Quality Control

From raw materials through the finished product, INDEECO maintains the highest standards in the industry through a series of Quality Control/Assurance checks.

- **Magnesium Oxide** – INDEECO uses only 96% pure MgO, the highest grade available for electric heating elements. Each batch is checked against two ASTM Standards: ASTM D3347 determines tap density to assure a high insulation density. ASTM D2755 is used for sieve analysis. Samples are sifted through ten progressively coarser sieves to assure a high concentration of larger grains, which have better thermal conductivity and dielectric strength. As a result, INDEECO elements have extremely high MgO density.
- **Certification to Special Standards** – Elements can be certified to Military Standards such as MIL-H-22577C and MIL-H-22594A, and special customer specifications regarding tolerances, hydrostatic testing, etc. Please consult the factory for details.

UL and CSA Recognition

Most of the elements described in this catalog are Recognized by the Underwriters Laboratories under UL Standard 1030. Our File No. is E78533. In addition, epoxy-sealed elements for refrigeration defrost are Recognized under File No. SA3254. Such recognition makes it simpler for manufacturers to incorporate INDEECO elements into equipment that is UL Listed. Tubular and finned tubular elements are also CSA approved under Report No. LR 11895-39. Please consult the factory for details.

Physical & Electrical Specifications

Physical & Electrical Specifications

Table I

| Description | Unfinned Tubular Elements | | | Finned Tubular Elements | |
|---|--|---------|----------|-------------------------|----------|
| | Standard | | Two-Pass | Standard | Two-Pass |
| | .312" | .475" | .475" | .475" | .475" |
| Sheath Materials⁽¹⁾ (Max Sheath Temp) | | | | | |
| Copper (seamless) (350° F) | Custom | Stock | Stock | N/A | N/A |
| Steel (750° F) | N/A | Stock | Stock | Stock | Stock |
| 304 SS (1400° F) | Stock | Stock | Stock | Stock | Stock |
| 316 SS (1400° F) | Custom | Stock | Stock | Stock | Stock |
| Inconel 625 (1800° F) | N/A | Stock | N/A | N/A | N/A |
| Incoloy 800 (1600° F) | Stock | Stock | Stock | N/A | N/A |
| Incoloy 800 (seamless) (1600° F) | N/A | Custom | N/A | N/A | N/A |
| 321 SS (seamless) (1400° F) | N/A | Custom | N/A | N/A | N/A |
| Monel 400 (1000° F) | N/A | Stock | Stock | Stock | Stock |
| Sheath Diameters | | | | | |
| Minimum | .309" | .469" | .469" | .469" | .469" |
| Maximum | .317" | .477" | .477" | .477" | .477" |
| Nominal Wall Thickness⁽²⁾ | .030" | .035" | .035" | .035" | .035" |
| Sheath Lengths | | | | | |
| Minimum | 11" | 11" | 11" | 11" | 11" |
| Maximum | 256" | 256" | 96" | 256" | 96" |
| Sheath Length Tolerances | 1% of overall sheath length with a minimum of 1/8" and a maximum of 1" | | | | |
| Cold Ends | | | | | |
| Minimum | 1-1/2" | 1-1/2" | 1-1/2" | 1-1/2" | 1-1/2" |
| Maximum | 24" | 28" | 16" | 28" | 16" |
| Maximum Current Draw | 40 | 40 | 30 | 40 | 30 |
| Maximum Voltage | 277 | 600 | 277 | 600 | 277 |
| Wattage Tolerance | +5/-10% | +5/-10% | +5/-10% | +5/-10% | +5/-10% |

(1) Stock – Material in stock.

Custom – Material is either stocked in small quantity or must be special ordered for each job.

(2) Other wall thicknesses available.

Watt Density & Sheath Selection

Watt Density & Sheath Selection

Watt density and sheath material are the two most critical factors affecting element life. Watt density (watts per square inch of heater surface area) determines heater operating temperature for a given set of conditions. The sheath material must be suitable for the corrosive conditions and the extreme temperatures of the application.

Watt density is calculated as follows:

$$\text{Watt Density} = \frac{\text{Element Wattage}}{3.14 \times \text{Element Diameter} \times \text{Heated Length}}$$

Element diameter and heated length are expressed in inches.

Heating Air and Other Gases – Charts A through C give maximum sheath temperatures for a range of watt densities and velocities. This data is based upon air at atmospheric pressure and a 75° F inlet air temperature. For higher inlet temperatures, the sheath temperature will increase accordingly. Contaminants in the air, while normally not affecting the sheath temperature, may require a more highly corrosion-resistant sheath and/or fin material. For heating compressed air and other gases, consult the factory or your local INDEECO representative for watt density and sheath recommendations.

Chart B

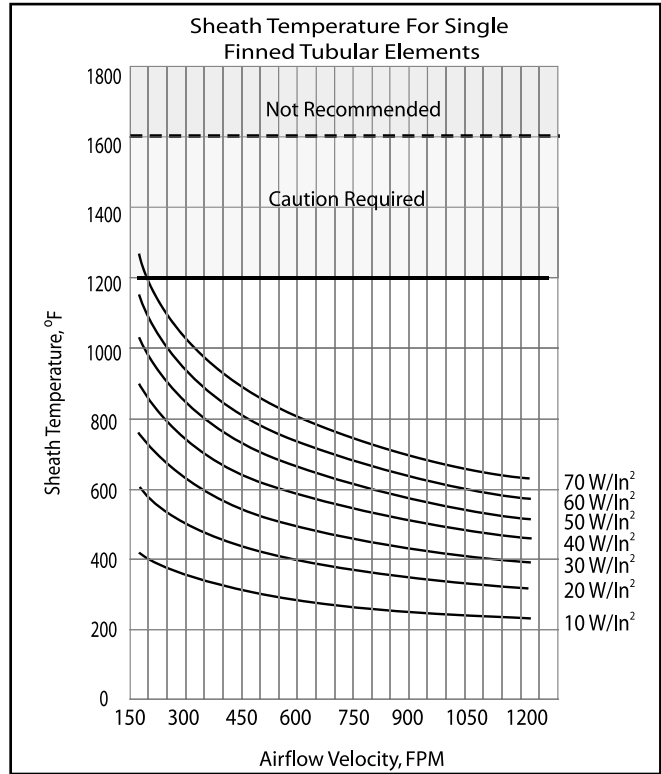

Chart A

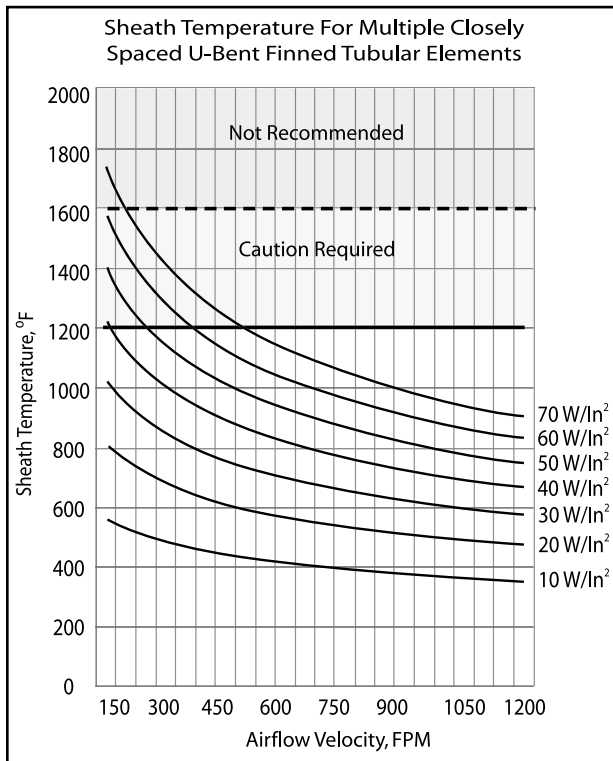
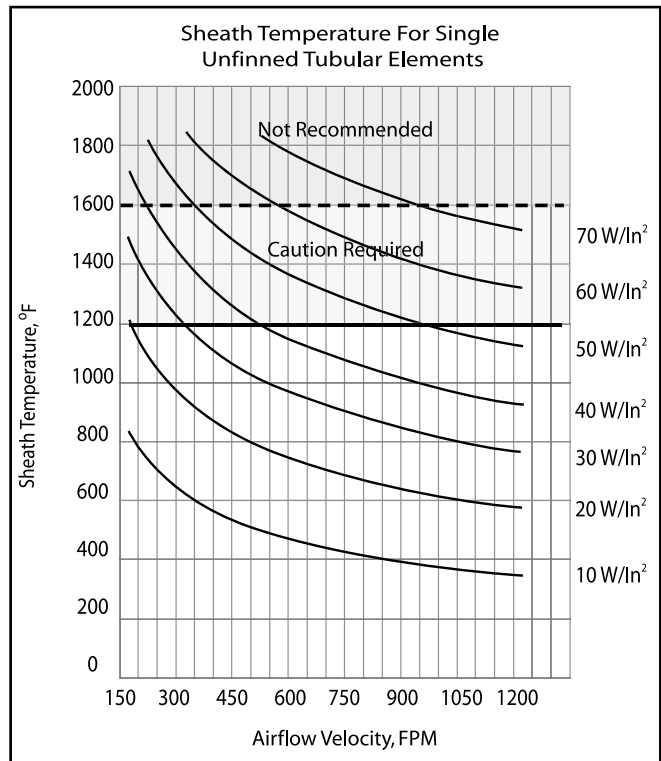

Chart C



Watt Density & Sheath Selection

Heating Liquids – Recommended watt densities and sheath materials for heating several common fluids are listed in Table II.

This information should be used only as a guide. INDEECO cannot be responsible for heater failures due to corrosion or excessive temperatures in the application.

Heating Metals – Table III gives recommended watt densities and sheath selection for elements that are clamped or inserted. Allowable watt densities will vary with such factors as element fit in a machined opening and metal thickness.

Watt Density & Sheath Materials

Table II

| Material | Maximum Fluid Temperature °F | Sheath Material | W/Sq. In. |
|---------------------|------------------------------|-----------------|-----------|
| Asphalt | 300 | Steel | 5-9 |
| Caustic Soda (50%) | 180 | 304 SS | 15 |
| Dowtherm A | 100 | Steel | 55-60 |
| | 200 | Steel | 40-50 |
| | 300 | Steel | 20-35 |
| | 500 | Steel | 3-5 |
| Ethylene Glycol | 200 | Steel | 30-40 |
| Fuel Oil, #5 & #6 | 200 | Steel | 5-12 |
| Lube Oil, SAE 10-30 | 250 | Steel | 15-20 |
| Lube Oil, SAE 40-50 | 160 | Steel | 5-12 |
| Oakites | 210 | Steel | 30-40 |
| Therminol 66 | 500 | Steel | 25-30 |
| | 600 | Steel | 20-25 |
| | 650 | Steel | 10-15 |
| Water-Potable | 100 | Copper | 75 |
| | 212 | Incoloy | 50-75 |
| Water-Deionized | 100 | 304 SS | 75 |
| | 212 | 304 SS | 50-75 |

For a comprehensive list of sheath materials compatible with fluids under a variety of conditions, refer to INDEECO Immersion Heater Catalog C70.

Table III

| Application | Maximum Metal Temperature °F | Recommended Watt Density W/Sq. In. | Recommended Sheath Material |
|---|------------------------------|------------------------------------|-----------------------------|
| Clamped to Flat Metal Surface | 200 | 20 | Steel |
| | 200 | 30 | 304 SS |
| | 400 | 20 | 304 SS |
| Inserted into Machined Grooves or Holes | 200 | 25 | Steel |
| | 200 | 35 | 304 SS |
| | 400 | 25 | 304 SS |
| | 600 | 20 | 304 SS |
| | 600 | 25 | Incoloy |
| | 800 | 15 | Incoloy |

Terminals, Insulators & Seals

Terminals, Insulators & Seals

Except as noted, various terminations, insulators and seals can be combined as required to fit the application.

Table IV

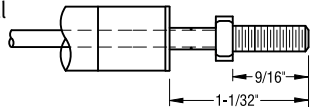
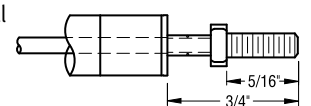
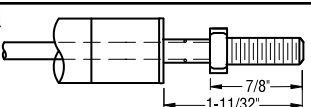
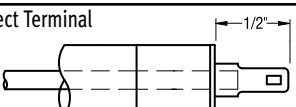
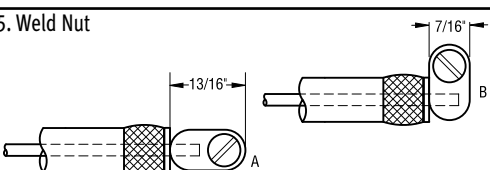
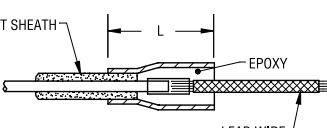
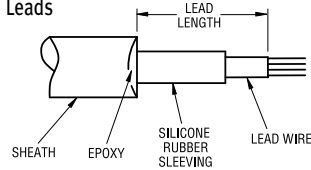
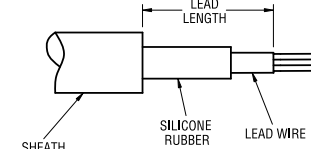
| Terminals | Description | Use | | | | | | |
|--|--|---|--------|-------|--------|-------|--|---|
| 1. Threaded Terminal (Standard)  | 10-32 stainless steel stud with 9/16" threaded length | For lead attachment in the field. 40 amp, 600V rating | | | | | | |
| 2. Threaded Terminal (Short)  | 10-32 stainless steel stud with 5/16" threaded length | For installations with tight clearance. | | | | | | |
| 3. Threaded Terminal (Long)  | 10-32 stainless steel stud with 7/8" threaded length | For multiple leads and heavy bus bars. | | | | | | |
| 4. Quick Connect Terminal  | Standard quick connect configuration | For connection to matching female terminal on field furnished lead. 30 amp, 600V rating | | | | | | |
| 5. Weld Nut  | Tab is welded to terminal pin and furnished with 10-32 terminal screw | Where it is more convenient to use this terminal orientation. | | | | | | |
| 6. Insulated Leads <table border="1" data-bbox="194 1239 357 1344"> <thead> <tr> <th>L</th> <th>Element Dia.</th> </tr> </thead> <tbody> <tr> <td>1-1/4"</td> <td>.312"</td> </tr> <tr> <td>1-3/4"</td> <td>.475"</td> </tr> </tbody> </table>  | L | Element Dia. | 1-1/4" | .312" | 1-3/4" | .475" | Standard copper conductors insulated with 5/64" or 1/16", 90° C neoprene | Used primarily with epoxy waterproof seal (see No. 14) for defrost applications. Rated 480V at the following amperages: 18 gauge – 10 amps max 16 gauge – 15 amps max 12 gauge – 30 amps max |
| L | Element Dia. | | | | | | | |
| 1-1/4" | .312" | | | | | | | |
| 1-3/4" | .475" | | | | | | | |
| 7. Silicone Insulated Leads  | Stranded nickel-clad copper leads with 1/32" silicone rubber insulation and glass braid | For higher temperature applications requiring a 200° C insulation. Rated 600V at the following amperages: 14 gauge – 20 amps 12 gauge – 30 amps | | | | | | |
| 8. Type TGGT Leads  | Stranded nickel-clad copper leads with Teflon – Glass – Glass – Teflon, 4-layer insulation | For applications requiring 250° C insulation. Rated 600V at the following amperages: 14 gauge – 20 amps 12 gauge – 30 amps | | | | | | |

Terminals, Insulators & Seals

Table IV (continued)

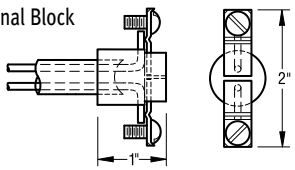
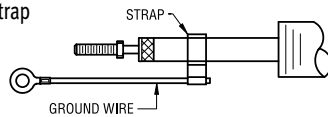
| Terminals | Description | Use |
|--|---|--|
| <p>9. Ceramic Terminal Block</p>  | 10-32 female terminal tabs spot-welded to terminal pins running through ceramic block | For .475" diameter two-pass elements where temperature exceeds insulation limit or for convenience in attaching field furnished leads. Rated 30 amps at 277V |
| <p>10. Grounding Strap</p>  | To ground long straight single-pass finned tubular elements, eliminating arcing due to secondary currents | Recommended for straight single-pass finned tubular elements over 6' long. |

Note: Terminations Nos. 1 through 8 are available on standard single-pass elements. Two-pass elements available with Nos. 9 and 15 only.

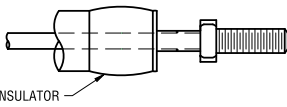
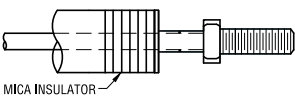
| Terminal Insulators | Use |
|---|---|
| <p>11. Silicone Rubber (Standard)</p>  | General applications where terminal temperatures do not exceed 400° F. 1/4" thick insulation furnished up to 250V; 1/2" thick up to 600V. (Standard insulator unless otherwise specified) |
| <p>12. Mica</p>  | Applications where terminal temperatures do not exceed 1000° F. 1/4" thick insulation furnished up to 250V; 1/2" thick up to 600V. |

Note: Terminal insulators are used in conjunction with Terminals Nos. 1 through 5 on standard elements.

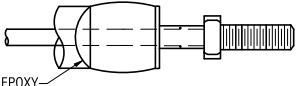
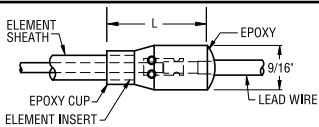
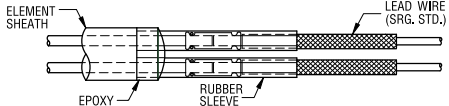
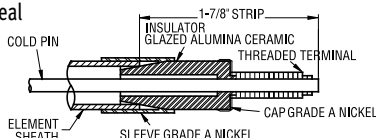
| Terminal Seals | Description | Use | | | | | | |
|---|---|---|--------|-------|--------|-------|--|--|
| <p>13. Epoxy Barrier</p>  | Epoxy resin is mostly absorbed by the magnesium oxide insulation, but a thick film forms a barrier against moisture | For applications where low to moderate humidity may be present in the terminal area. For use at 200° F maximum. | | | | | | |
| <p>14. Epoxy Seal</p> <table border="1" data-bbox="146 1302 324 1417"> <thead> <tr> <th>L</th> <th>Element Dia.</th> </tr> </thead> <tbody> <tr> <td>1-1/4"</td> <td>.312"</td> </tr> <tr> <td>1-3/4"</td> <td>.475"</td> </tr> </tbody> </table>  | L | Element Dia. | 1-1/4" | .312" | 1-3/4" | .475" | Epoxy resin fills a metallic adapter enclosing the connection between lead wire and element terminal pin | Primarily defrost applications and others where water may drip on the terminal end. UL Recognized under File SA3254. Suitable for a maximum adapter temperature of 200° F. |
| L | Element Dia. | | | | | | | |
| 1-1/4" | .312" | | | | | | | |
| 1-3/4" | .475" | | | | | | | |
| <p>15. Epoxy Barrier (for two-pass construction)</p>  | Epoxy resin is mostly absorbed by the magnesium oxide insulation, but a thick film forms a barrier against moisture | For applications where low to moderate humidity may be present in the terminal area. For use at 200° F maximum. | | | | | | |
| <p>16. Hermetic Seal</p>  | Ceramic to metal hermetic seal is soldered to the element sheath and terminal pin. 1/4"-28 threaded terminal | Absolute seal up to 1000° F. | | | | | | |

Bending

Bending

Standard single-pass tubular elements may be bent in an infinite variety of configurations. Utilizing the most up-to-date computer numerical control (CNC) bending equipment and techniques, INDEECO is able to produce an element to fit virtually any application.

Bends that are less than 2" center-to-center are normally repressed on unfinned elements to recompact the magnesium oxide insulation, eliminating hairline cracks that may develop during bending.

Figures A through T show some of the configurations frequently specified. For configurations not shown, submit a drawing or sketch of your requirements. Any of these are available either finned or unfinned.

Table V

| Sheath Diameter (Inches) | Sheath Materials | Minimum Bending ⁽¹⁾ (Inches) | | Center-To-Center Dimensions (Inches) Available For Repressing Dies For 180° Bends |
|--------------------------|--|---|-----------------------------|--|
| | | Inside Radius | Center-To-Center Dimensions | |
| .312 | Copper & Incoloy 800 304 SS | 3/8 | 7/8 | 5/8, 11/16, 3/4, 1, 1-1/2, 2, 2-3/8, 2-1/2 |
| | | 1/4 | 1 | |
| .475 Unfinned | Copper, Steel & Incoloy 800 304 & 316 SS Inconel 600 & Monel 400 | 1/2 | 1-1/4 | 1, 1-1/16, 1-1/8, 1-1/4, 1-3/8, 1-1/2, 1-5/8, 1-3/4, 1-7/8, 2, 2-1/4, 2-1/2 |
| | | 1/4 | 1 | |
| | | 3/8 | 1-1/2 | |
| .475 Finned | Steel 304 SS Monel 400 | | 2 | Not repressed. Bending dies are available in 1/8 increments from 2 through 3-1/2. |
| | | | 2 | |
| | | | 2 | |

(1) Contact factory for requirements below minimum bending dimensions shown.

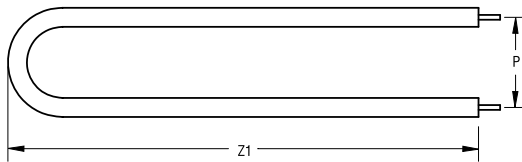

Figure A

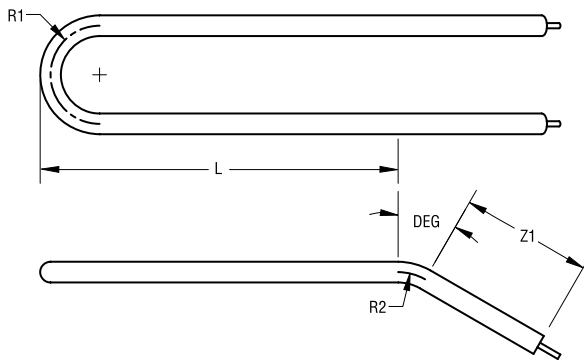
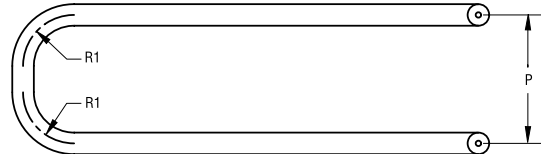

Figure B

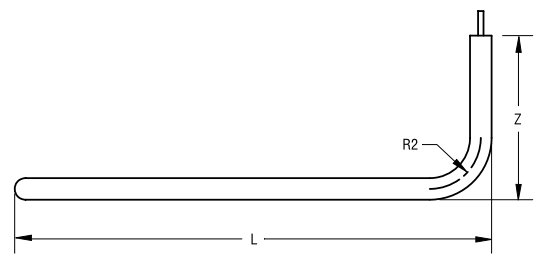

Figure C

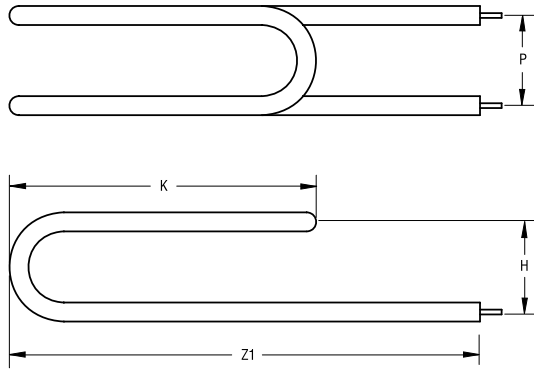

Figure D

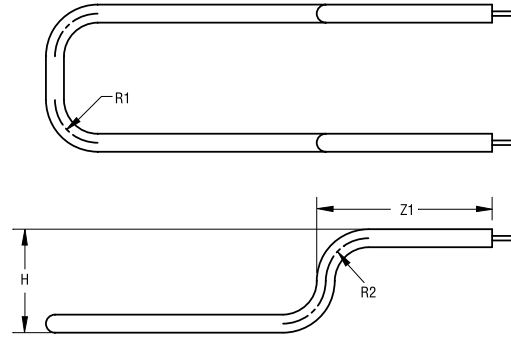

Figure G

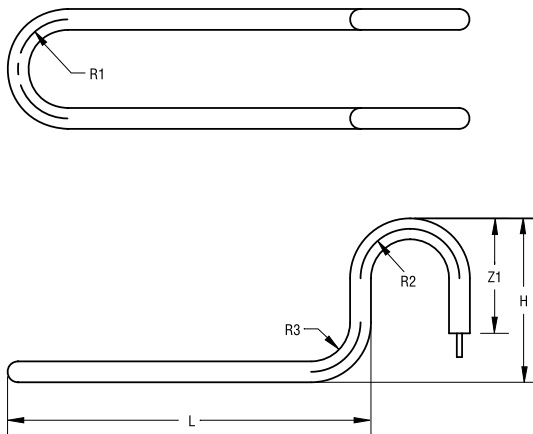

Figure E

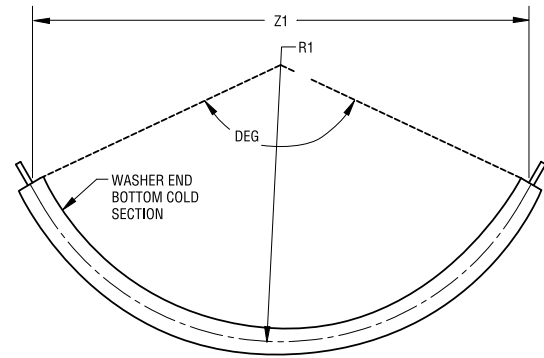

Figure H

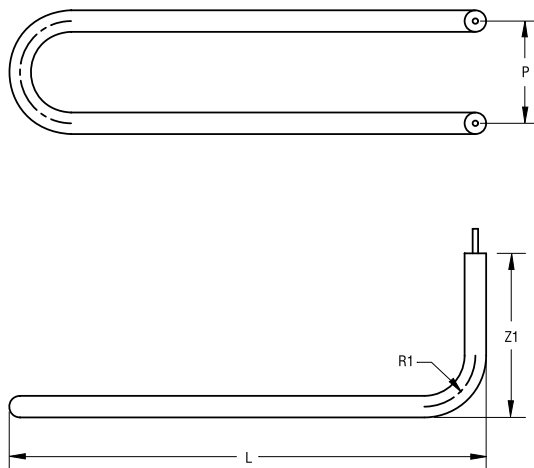

Figure F

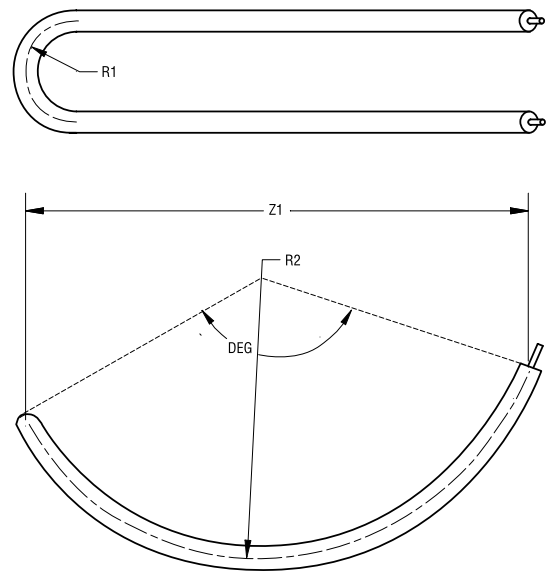

Figure I

Bending

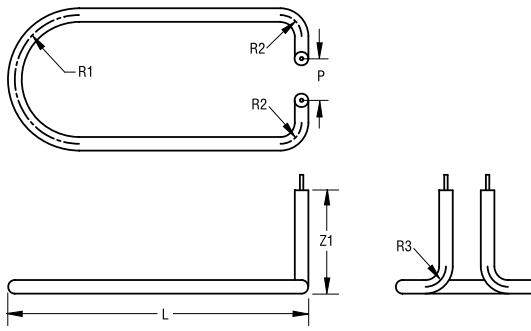

Figure J

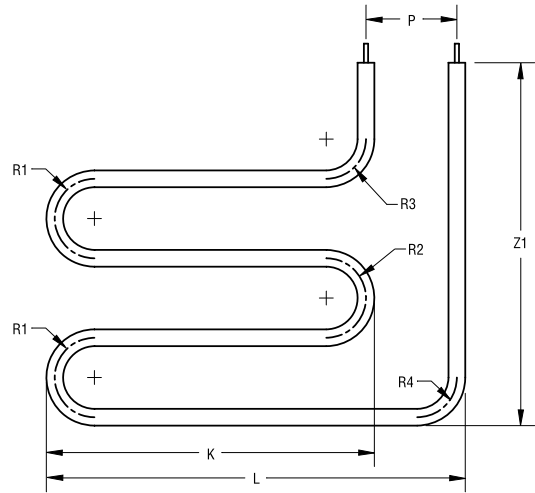

Figure M

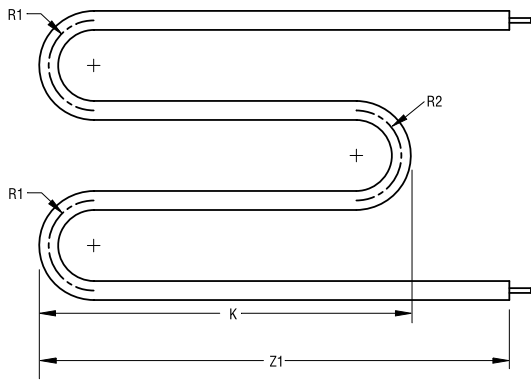

Figure K

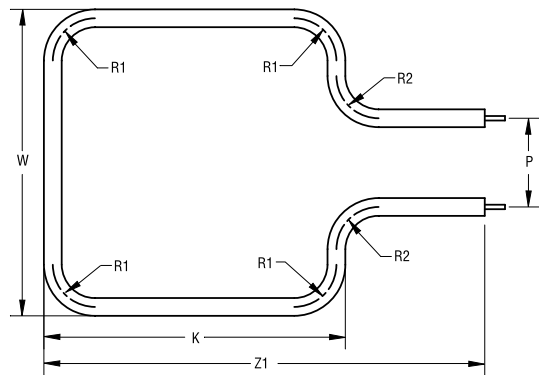

Figure N

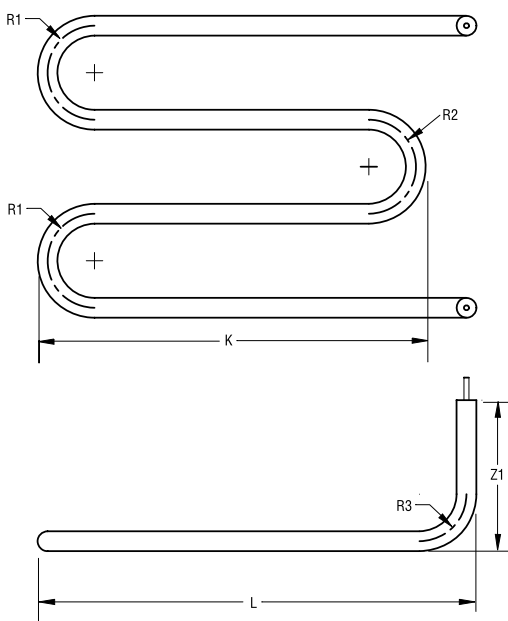

Figure L

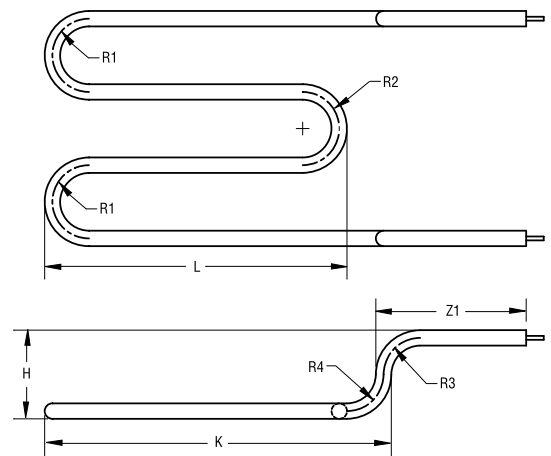

Figure O

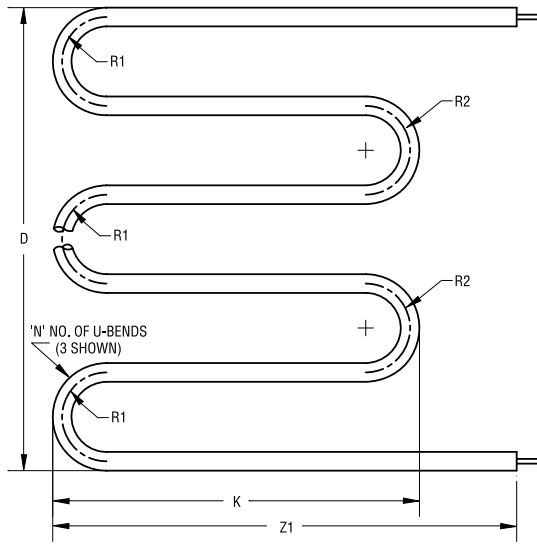

Figure P

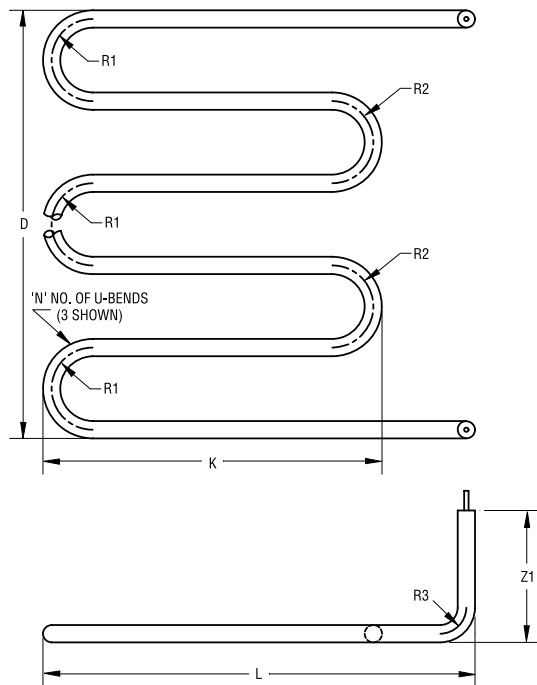

Figure Q

Note: Unheated section must not end in bend.

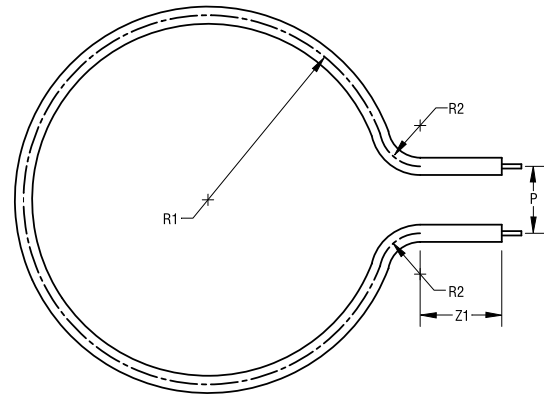

Figure R

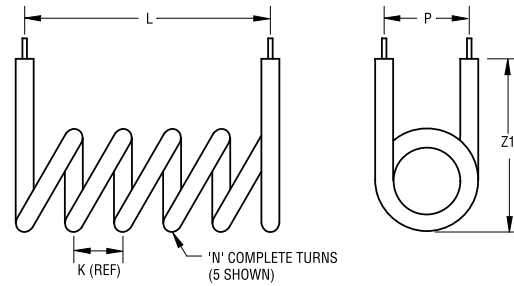

Figure S

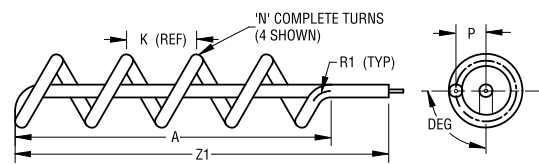

Figure T

Mounting Accessories

Mounting Accessories

Two types are available: Threaded Fittings and Mounting Plates.

Threaded Fittings

Threaded fittings are furnished with nuts and optional fiber gaskets, washers and lockwashers. They are designed for immersion applications. Fittings are silver soldered, welded or mechanically pressed (staked) to the sheath. Welding requires sheath and fitting material compatibility. Standard elements require two fittings, one for each terminal end. Two-pass elements require only one fitting.

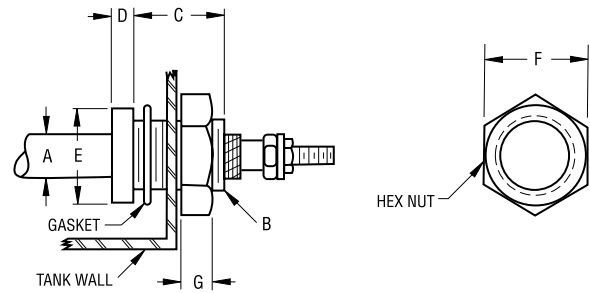

Dimensional details shown in Table VI

Table VI

| Fitting Part No. | Material | A (Inches) | B (Thread Size) | C (Inches) | D (Inches) | E (Inches) | Hex Nut (Inches) | |
|------------------|-----------|------------|-----------------|------------|------------|------------|------------------|------|
| | | | | | | | F | G |
| 1007139 | Brass | 0.312 | 1/2 - 20 | 7/8 | 5/16 | 3/4 | 3/4 | 5/16 |
| 1007219 | Brass | 0.312 | 9/16 - 18 | 1/2 | 1/8 | 1 | 7/8 | 5/16 |
| 1007142 | Brass | 0.312 | 5/8 - 18 | 1/2 | 5/16 | 1 | 7/8 | 1/8 |
| 1007215 | Steel | 0.312 | 3/4 - 16 | 1-1/16 | 1/4 | 1 | 1 | 3/16 |
| 1007127 | Brass | 0.475 | 5/8 - 18 | 9/16 | 5/16 | 1 | 7/8 | 1/8 |
| 1007225 | Brass | 0.475 | 3/4 - 16 | 7/8 | 1/4 | *1 | 1 | 1/8 |
| 1007228 | Stainless | 0.475 | 3/4 - 16 | 7/8 | 1/4 | *7/8 | 7/8 | 1/8 |
| 1007279 | Stainless | 0.475 | 3/4 - 16 | 3/8 | 3/16 | *1 | 7/8 | 1/8 |
| 1006846 | ***Steel | 0.475 | 5/8 - 18 | 1/2 | 1/8 | 1 | 7/8 | 1/8 |
| 1000058 | **Steel | 0.475 | 3/4 - 16 | 1/2 | 1/8 | *7/8 | 1 | 3/16 |
| 1007249 | Steel | 0.475 | 3/4 - 16 | 1-1/16 | 3/16 | *1 | 1 | 3/16 |

* These fittings have a hex flange instead of a round flange.

** This fitting is copper plated steel, normally furnished on finned tubular elements with palnut type locknuts standard. Gaskets are not furnished unless specified.

*** This fitting is nickel plated steel, with palnut type locknuts standard.

Mounting Plates

Mounting plates provide a simple, convenient means of holding elements in place in an airstream and other applications where the element is not immersed in a liquid. Stainless steel plates are mechanically pressed (staked) or tack welded to stainless sheathed elements; copper-plated steel plates are brazed to steel sheathed elements.

The mounting plates shown to the right are for .475" diameter elements. Consult factory for .312" diameters.

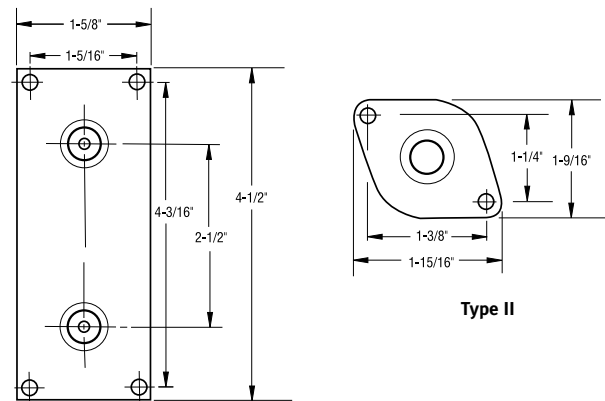

Type I

Type II

Table VII

| Heating Element Configuration | Mounting Plate | |
|-------------------------------|----------------|-----------|
| | Type | Material |
| 2-1/2" C-C U-Bent | I | Steel |
| 2-1/2" C-C U-Bent | I | Stainless |
| Straight or Two-Pass | II | Steel |
| Straight or Two-Pass | II | Stainless |

Limited Warranty

Industrial Engineering and Equipment Company (INDEECO) products are warranted against defects in workmanship, material, design, labeling and packaging. No other warranty, expressed or implied, written or oral, applies. No person other than an officer or the general manager of INDEECO is authorized to give any other warranty or assume any liability.

Warranty Period: This warranty is effective for eighteen months from the date of shipment of the product from INDEECO's factory, or for twelve months from the date the product is first placed in service, whichever period lapses first.

Conditions of Warranty: INDEECO products must be installed, operated and maintained in accordance with INDEECO's instructions. INDEECO is not liable for damage or unsatisfactory performance of the product resulting from accident, negligence, alteration, unauthorized repair, improper application or installation of the product, improper specifications or corrosion. INDEECO IS NOT LIABLE FOR ANY INCIDENTAL OR CONSEQUENTIAL DAMAGES. Claims against carriers for damage in transit must be filed by the purchaser with the carrier.

Remedy: The part or product in question should be returned, freight prepaid, to:

INDEECO

425 Hanley Industrial Court
St. Louis, Missouri 63144
Attention: Return Goods Manager

If after receipt of the product and the claim, INDEECO finds to its reasonable satisfaction that the product is defective in workmanship, material, design, labeling or packaging, the product will be repaired or replaced or the purchase price refunded at INDEECO's option. There will be no charge to the purchaser for parts or labor. Removal and reinstallation of the product, and shipment of the product to INDEECO for repair or inspection shall be at the purchaser's risk and expense.

THE REPAIR, REPLACEMENT OR REFUND PROVIDED FOR IN THIS LIMITED WARRANTY IS THE EXCLUSIVE REMEDY OF THE PURCHASER. THIS WARRANTY IS EXPRESSLY IN LIEU OF ANY OTHER WARRANTIES, EXPRESSED OR IMPLIED, INCLUDING ANY WARRANTY OF MERCHANTABILITY OR FITNESS FOR A PARTICULAR PURPOSE. THERE ARE NO WARRANTIES WHICH EXTEND BEYOND THE TERMS OF THIS LIMITED WARRANTY.

Thermal Products, Inc.
964 A Route 146
Clifton Park, NY 12065
(518) 877-0231
sales@thermalproducts.com
www.thermalproducts.com



INDUSTRIAL ENGINEERING & EQUIPMENT CO.

425 HANLEY INDUSTRIAL COURT

ST. LOUIS, MO 63144

314-644-4300

Fax: 314-644-5332

www.indeeco.com

FOR YOUR NEAREST INDEECO REPRESENTATIVE CALL:

800-243-8162