



DIESEL RUNAWAY PROTECTION SYSTEMS

FEATURES

- COMPACT RUGGED DESIGN
- NEMA 4 (WATERTIGHT)
- CSA CERTIFIED
- UL LISTED

HOW TO ORDER

- SPECIFY AMOT *SPEEDTRAP* 10424X (VALVE WITH MOUNTING BRACKET)

Model 10424X is used to link the truck's air supply and the *SPEEDTRAP* air intake shutoff valve in applications where the truck may encounter off-road services or extreme vibration. Pressure will be sent through Port "P" to Port "A" which will close *SPEEDTRAP* Model 4261 intake air shutoff valve. When de-energized, pressure will be vented through Port "A" to Port "E".

INSTALLATION

MOUNTING

Model 10424X can be mounted on virtually any upright surface. Mount the valve where it is easily accessible for wiring and or testing. Model 10424X should be mounted in a position such that Port "A" faces upward (on a vertical axis).

3-Way Solenoid Air Valve

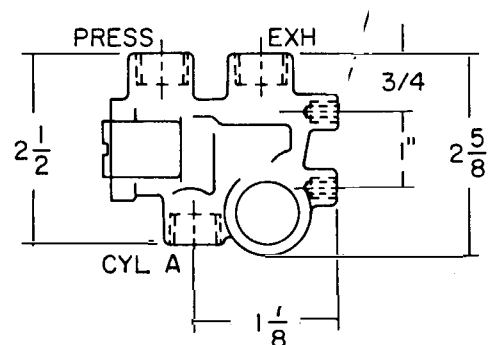
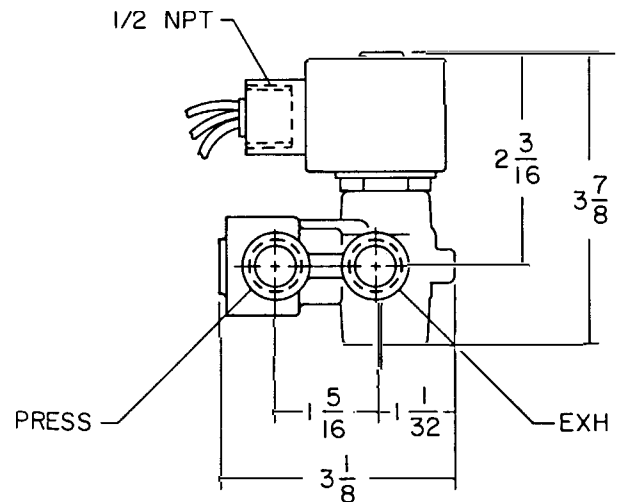

WIRING & PIPING

Two red wires are mounted to terminals 2 and 7 of *SPEEDTRAP* Electronic Speed Switch 8210J. Green wire is a chassis ground. All valve connections are made with 1/4" pipe thread fittings. A quality thread sealant such as Loctite™ should be applied. Teflon tape can be used but must be applied such that threads of the tape do not enter the valve. Port "P" is piped to a constant air supply. Port "A" is piped to AMOT 4261 Intake Air Shutoff Valve. Port "E" is open to atmosphere.

MAINTENANCE

SPEEDTRAP 10424X requires no maintenance. However, periodic testing is suggested as with any safety control system.

SPECIFICATIONS

Power Supply 10.2 - 12.6 VDC
 Pressure Requirements 50 - 200 psi
 Temperature 0° - 120°F
 (18° - 49°C)
 Response Time 5.10 milliseconds
 Valve Body Brass
 Valve Seals Buna N
 Valve Piston 303 SS
 Pressure Connections 1/4" NPT
 Mounting Threads 1/4 - 2 0 x 3/8" deep
 Approvals CSA & UL listed

TYPICAL APPLICATION

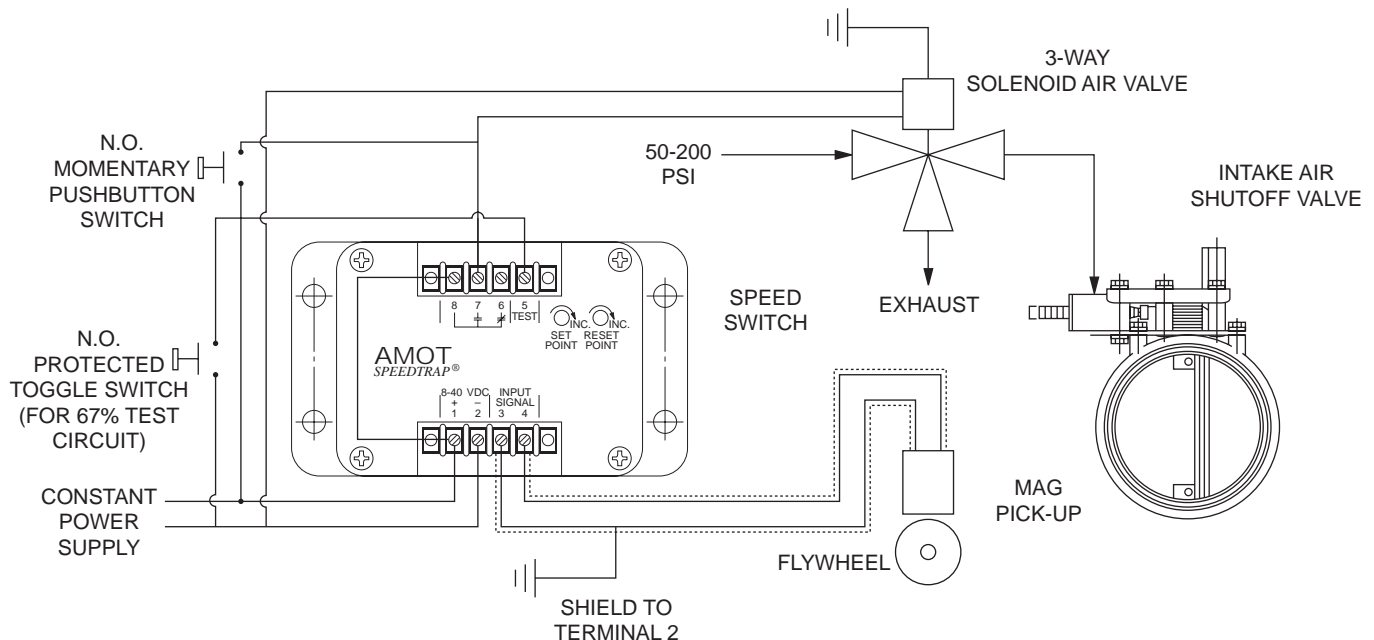

Accessories for Complete Runaway Protection

- AMOT *SPEEDTRAP* Installation Kit 8210KIT2 (includes shielded cable, magnetic pickup adapter bushing, dash mount test switch, pushbutton, and dash labels)
- AMOT *SPEEDTRAP* 4261 Intake Air Shutoff Valve
- AMOT *SPEEDTRAP* 8210J Speed Switch
- AMOT *SPEEDTRAP* 11408 Magnetic Pickup

AMOT Controls Corporation
 401 First Street
 Richmond, CA 94801
 Tel: (510) 236-8300
 Fax: (510) 234-9950

AMOT Controls Ltd.
 Western Way
 Bury St. Edmunds IP33 3SZ
 Suffolk England
 Tel: (0284) 762222
 Fax: (0284) 760256

AMOT Controls Corporation
 230 Orchard Road
 # 09-230 Faber House
 Singapore 0923
 Tel: (65) 235-8187
 Fax: (65) 235-8869