



Thermal Products, Inc.
 964 A Route 146
 Clifton Park, NY 12065
 (518) 877-0231
 sales@thermalproducts.com
 www.thermalproducts.com

ProSonix™ J-Series – PSX Jet Sparger Tank or Inline Process Piping Mount Design ...

J-Series Jet Sparger ...

- **Tank Heating:** PSX Jet Sparger is designed to mount on a tank or vessel for fluid or slurry heating applications.
- **Inline Heating:** PSX Jet Sparger is designed to be mounted in your existing process piping for continuous water or slurry heating applications.
- **Operation:** Open/Close double acting air cylinder controls the flow of steam through the Jet Sparger. Optional Modulating steam flow design also available.
- **Control:** Plant air signal of 60 psig required for operation.
- **Temperature Control:** Integrates well with customers temperature control loop.
- **Compact design** suitable for minimal installation space requirements. Can be installed in any orientation.
- **MOC:** Standard materials of construction are carbon steel and 316SS or special alloys upon request.
- **Connection:** Standard 150 psig RF flange for steam and tank connection. 300 psig available as an option.
- **Single or Multiple** unit configurations.

Features & Benefits

High velocity steam delivery assures complete mixing of steam, reducing occurrences of vibration, and saves energy losses from uncondensed steam escaping. Integral stem plug eliminates need for steam pressure control valve. Can be installed in your existing tank flange, or simply by adding a flanged inlet to your process piping.



Patent Pending

Jet Sparger – Internal View

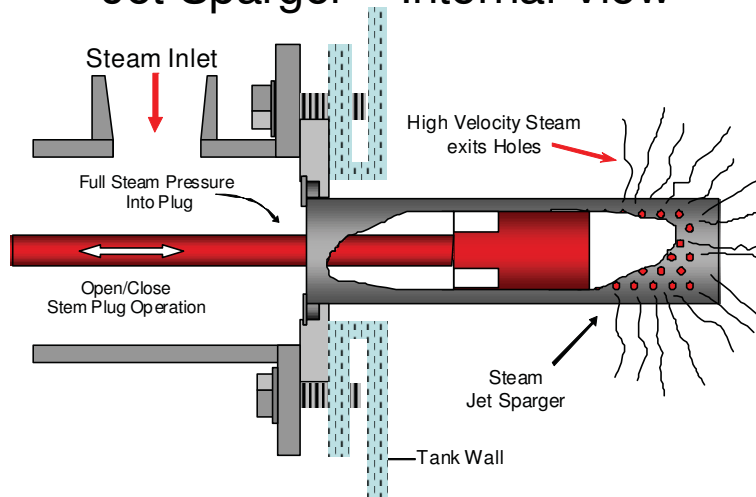

How It Works ...

The **ProSonix™ J-Series Jet Sparger** is designed for water and slurry heating for both tank and inline applications. The unique design of internal steam control allows the PSX Jet Sparger to deliver high velocity steam to promote rapid condensation and mixing of the steam. An internal stem plug opens and closes to inject steam through the engineered diffuser.

PROSONIX
 P.O. Box 26676 • Milwaukee, WI 53226-0676
 p.800.849.1130 • f.800.849.1130
 www.pro-sonix.com

PSX J-Series 1209



Thermal Products, Inc.
 964 A Route 146
 Clifton Park, NY 12065
 (518) 877-0231
 sales@thermalproducts.com
 www.thermalproducts.com

J-Series - Available Configurations ...

On/Off Operation - The dual acting air cylinder (ATO/ATC) is applications where on/off service is most appropriate.

Modulating DA - The modulating actuator allows for linear steam flow control and is used in situations where temperature control is most important. The Jet Diffuser comes in extension lengths from 12" – 36" for tank or large pipe/high flow applications.

Modulating PA – The J-Series will utilize an integral Pneumatic Actuator where difficult to pump and heat fluids are present.

Manual Operation – The J-Series can be used without plant air with steam control via a manually operated hand wheel.

Typical Installation Diagram

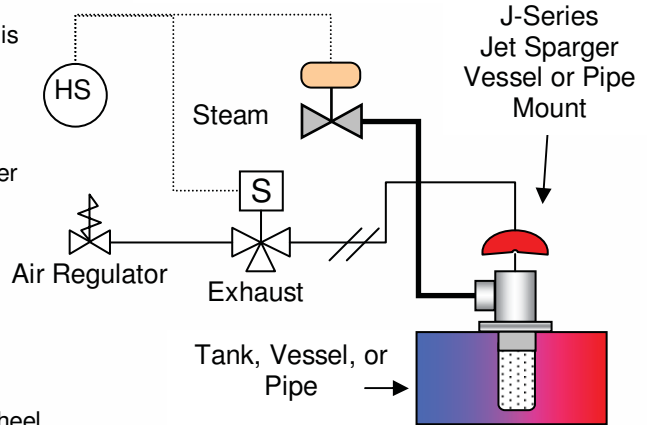

J-Series Connections & Steam Flow Capacities						
Model	Steam Inlet	Pipe/Tank Flange Connection	PSX Jet Sparger Diameter	Typical Minimum Pipe diameter	Steam Capacity @ 30 PSIG (pph)	Steam Capacity @ 100 PSIG (pph)
PSX100-J	1.0" NPT	3.0"	1.5"	3	870	2,365
PSX200-J	2.0" NPT	4.0"	2.375	4	2,180	6,073
PSX300-J	3.0" RF	4.0"	3.5"	6	5,295	14,600
PSX400-J	4.0" RF	6.0"	4.5"	8	9,550	26,340
PSX600-J	6.0" RF	8.0"	6.5"	10	18,500	51,100

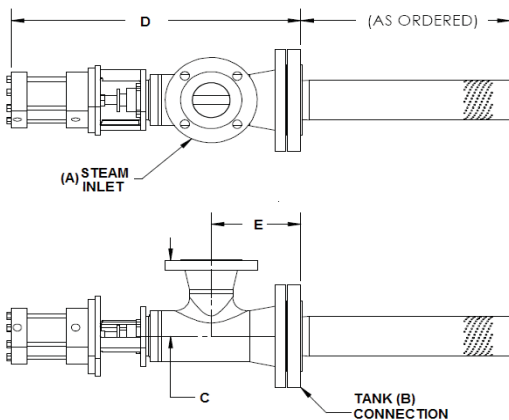

ProSonix J-Series Dimensions

Model	A	B	C	D	E
PSX-100J	1" NPT	3" RFF	3.12"	20.25"	5.5"
PSX-200J	2" NPT	3" RFF	3.75"	21"	6"
PSX-300J	3" RFF	4" RFF	6.7"	23.6"	7.3"
PSX-400J	4" RFF	6" RFF	8.4"	29.3"	9.5"
PSX-600J	6" RFF	8" RFF	10.2"	35.4"	14.5"

Above dimensions are for reference only and not for construction. Please contact ProSonix for current dimensional print.

Common Applications ...

- Tank or Vessel Steam Sparging
- Vent Steam Recovery
- Continuous Inline Heating
- Water or Slurry Heating
- Boiler Feedwater Pre-heating
- Supplemental Hot Water Needs
- Seasonal Heating Applications
- Large Pipe/Small Temp Needs

For Additional Information, Please Visit Us At ... www.pro-sonix.com

PROSONIX
 P.O. Box 26676 • Milwaukee, WI 53226-0676
 p.800.849.1130 • f.800.849.1130
www.pro-sonix.com

PSX J-Series 1209